

# lights and heaters

## Step 1

remove all packaging from in and around umbrella

## Step 2

pull pin from cam lock and lift the handle to unlock umbrella

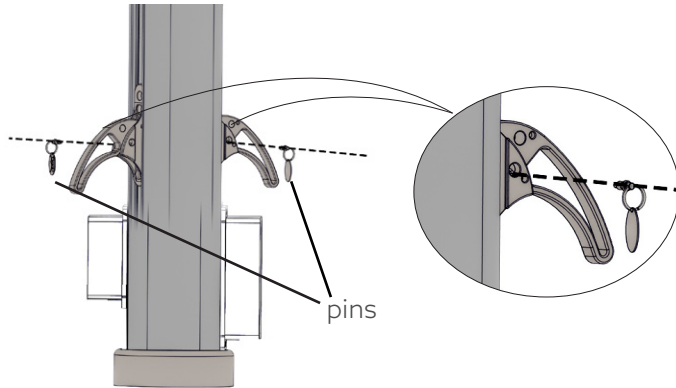

## Step 3

once you have leveled the stem using the base installation instructions, slide the beauty cover and umbrella over the security stem (security stem is included with umbrella).

**Note:** Ensure that cables are not pinched when inserting the umbrella over the security stem and when installing the beauty cover.

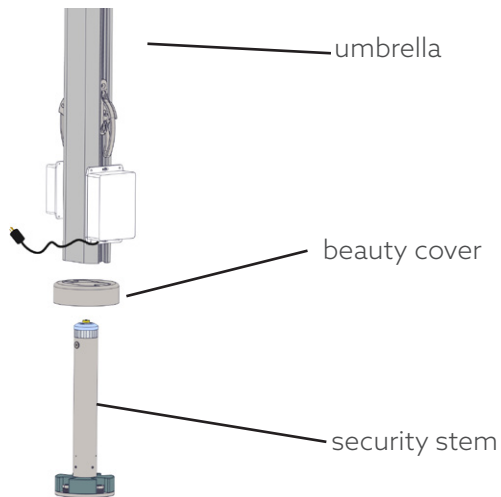

## Step 4

lock umbrella down by pushing the cam lock handles in the down position and lock with pins. Mount beauty covers over control boxes.

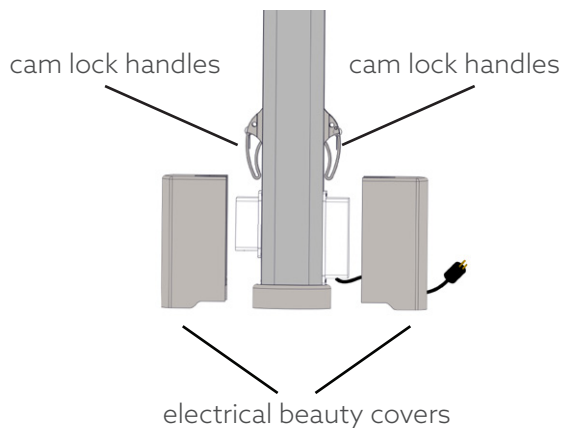

# mounting dual canopy frame

## Step 5

For shipping purpose trolley carts are tighten with elastic rope.  
Remove protective bubble wrap and elastic rope.

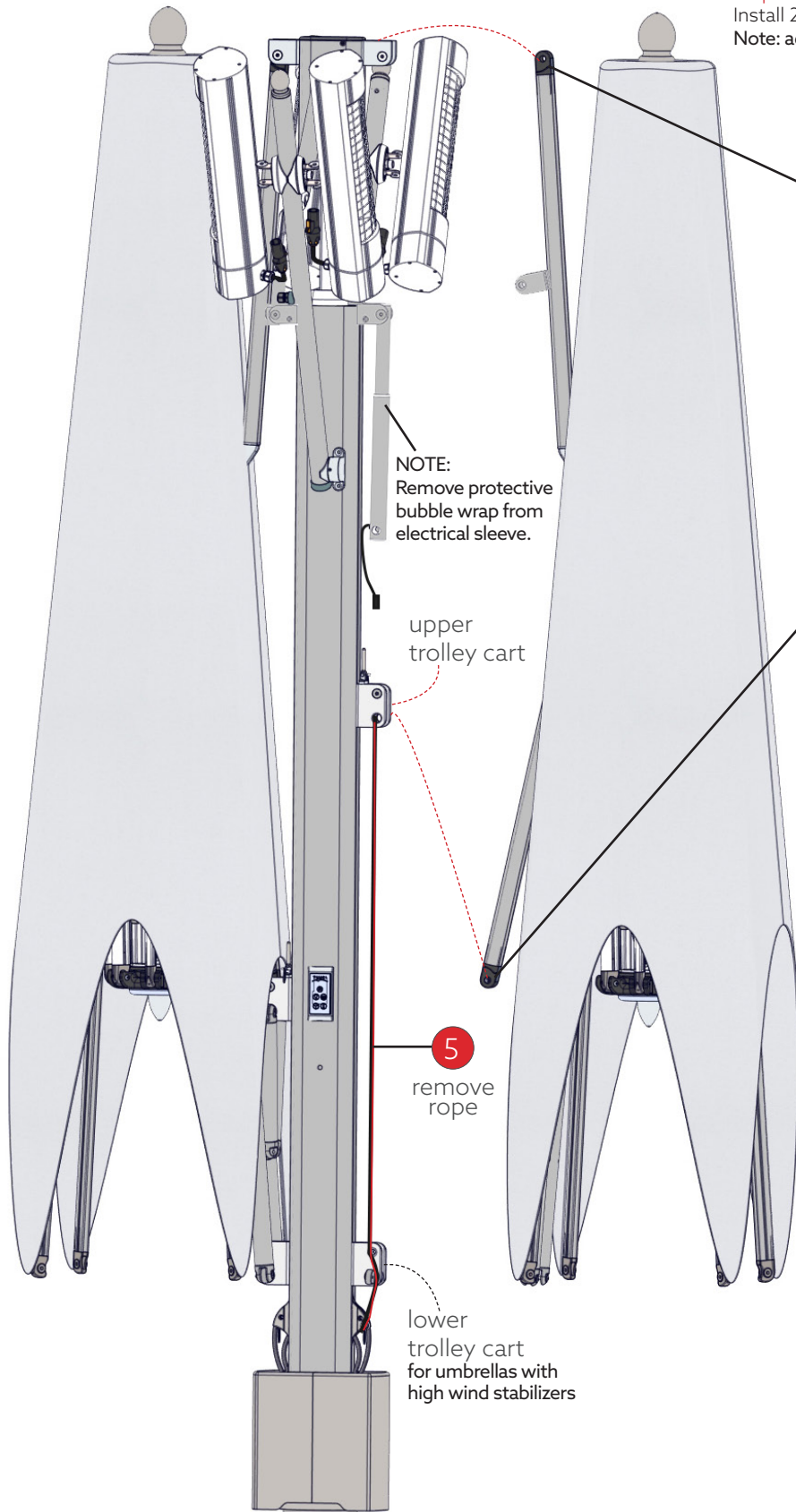

## Step 6

Install 2nd canopy frame by using the 3/8" bushings and screws.  
Note: add a drop of provided loctite to the end of the screw threads.

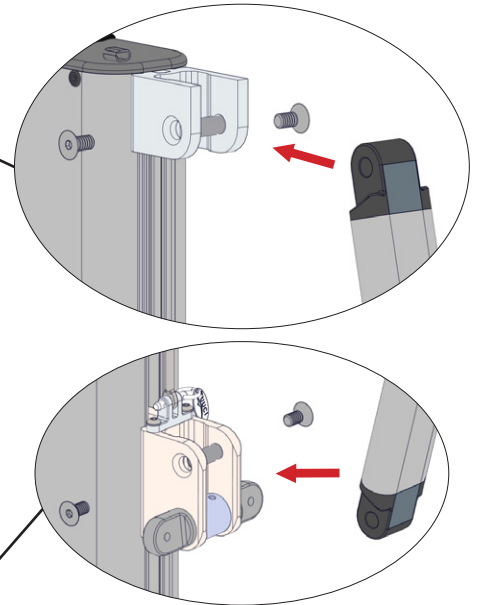

## Step 7

If applicable connect high wind stabilizers.

- Mount long arms wind stabilizers to lower trolley cart
- Mount short arms wind stabilizers to upper trolley cart.

Note: add a drop of provided loctite to the end of the screw threads.

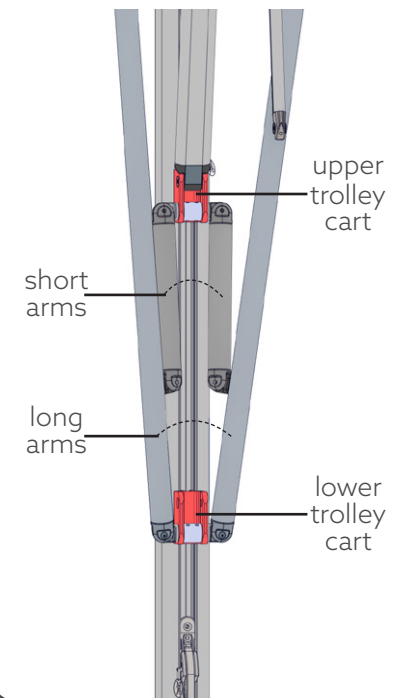

# electrical sleeve connection



## Step 8

mount electrical sleeve to scissor bracket with 3/8" bushing and 3/8"-16 flat head screw

Note: add a drop of provided loctite to the end of the screw threads.

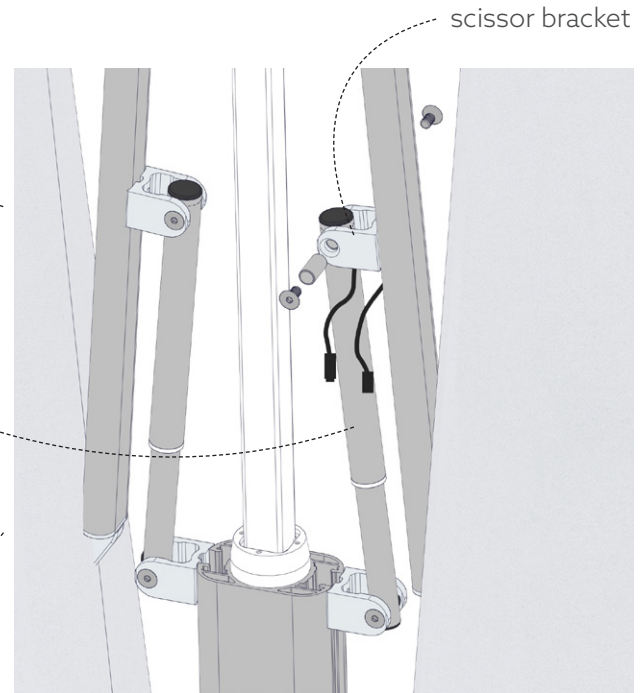

## Step 9

Connect cable from electrical sleeve to scissor cable

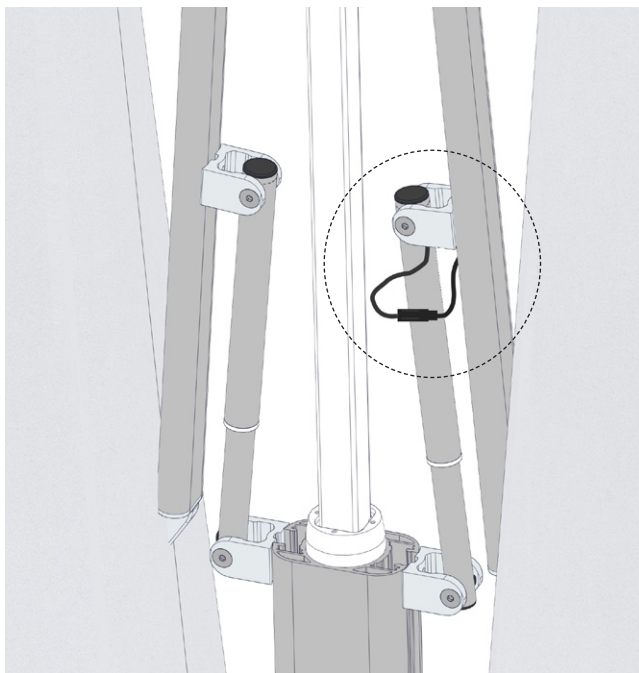

## Step 10

push in cable and connector through scissor grommet hole

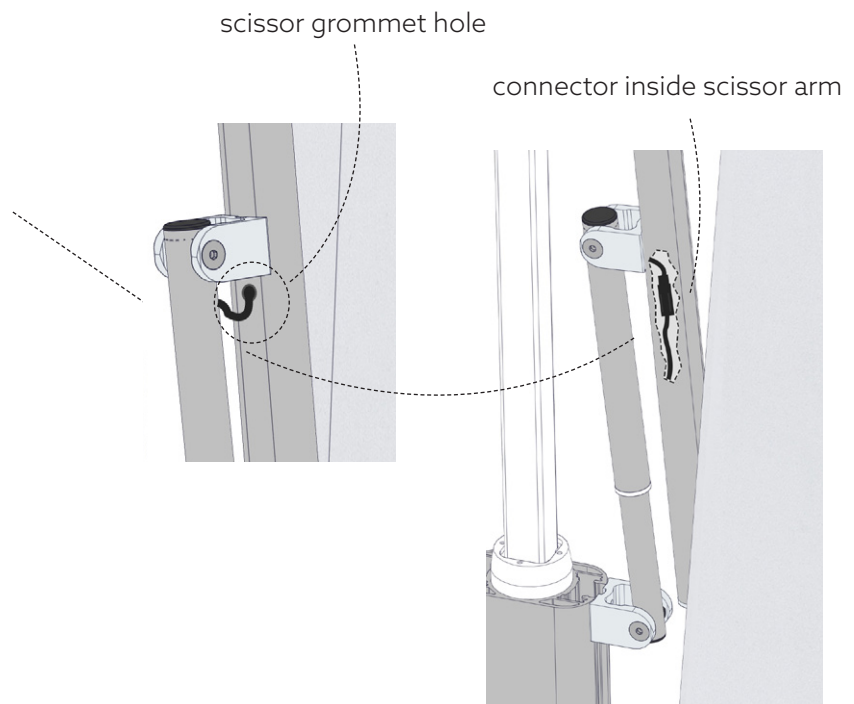

# lights and heaters



## Step 11

Plug in the cord of your umbrella into 220V receptacles. The TUUCI logo on the control panel will be backlit in white, when the umbrella is properly plugged into the power source.



## Step 12

Press the Power button on the control panel to turn on the umbrella. The button will be backlit in red when the power is ON. In addition, when the umbrella is ON, the light icon and heater icon on the control panels will be backlit in white.

## Step 13

Make sure the gear lock button is in the top (unlocked) position before turning the crank handle.

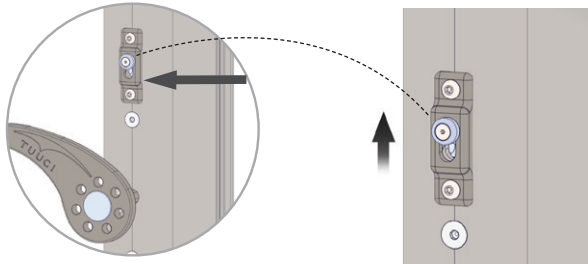

## Step 14

Insert and rotate the crank handle counter-clockwise until the cable connector is in line with the cable bracket.

**Note:** The canopies and umbrella will remain closed. It is Important to keep tension on the cable connector as you continue turning the crank in a counter-clockwise position.

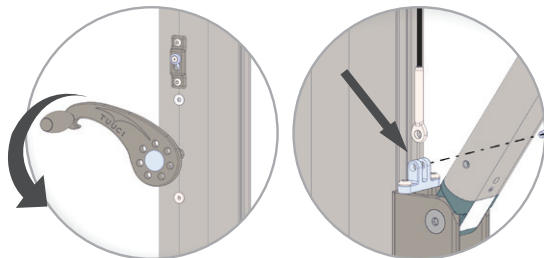

## Step 15 for each umbrella canopy

- While the umbrella is still closed make sure the telescope is fully extended out from the mast.
- Pull the security pin from the trolley car bracket.
- Pull the cable connector so it aligns with the trolley car bracket.
- Fasten the cable connector to the trolley bracket with the security pin.

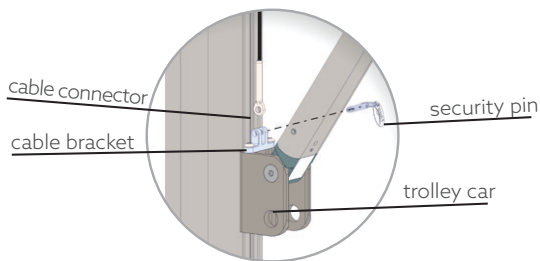

## Step 16

Gently separate each rib individually from the center hub approximately 10 inches. If the rib does not move easily, do not force. Inspect the product for additional packaging.

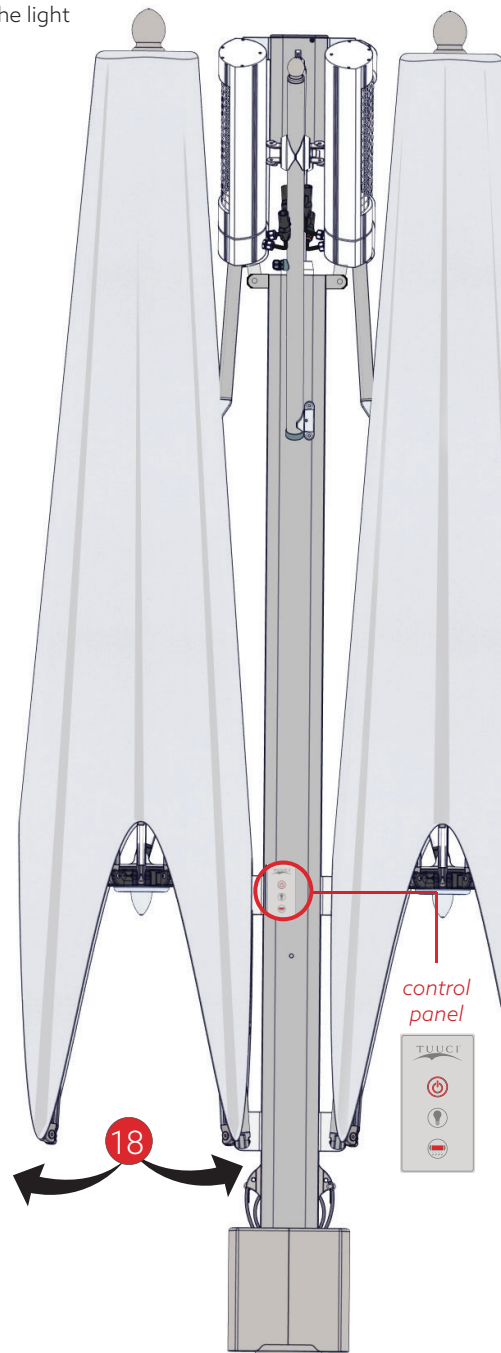

## CAUTION

Ensure that your umbrella is level (not tipped or tilted). For safety reasons, If the umbrella is tipped, you will not be able to turn-on the Ambia LED light and/or heaters.

Ensure that there is nothing blocking the canopy of the umbrella from being fully opened.

# lights and heaters

## TURN ON LIGHTS AND HEATERS



### Turning the Ambia LED lights on

Press the light bulb icon button on the control panel to turn-on the Ambia LED lights under each canopy. The color will change from white to blue after pressing the button, signaling that the lights are ON.

The umbrella canopies must be fully opened for 5 seconds before the Ambia LED lights and/or heaters can be turned on.

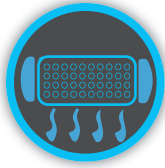

### Turning the heaters on

Press the heater icon button on the control panel to turn-on the heaters under each canopy. The color will change from white to blue, signaling that the heaters are ON.

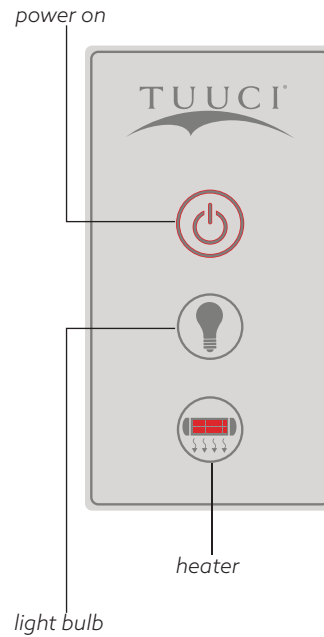

## CLOSING UMBRELLA CANOPIES

Instructions to turn-off the Ambia LED light and (4) heaters.

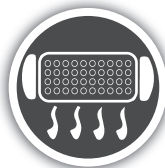

### Step 1

Press the heater icon button on the control panel to turn-off the heaters. After pressing the button it will be flashing for 2 minutes, then color will change to white, signaling that the heaters are OFF.



### Step 2

Press the light bulb icon button on the control panel to turn-off the Ambia LED lights. After pressing the button, the color will change to white, signaling that the lights are OFF.



### Step 3

Press the power button on the control panel to turn off the umbrella.

### Step 4

Close the umbrella with tie-back when not in use.

### NOTE:

Umbrella should not be closed entirely until all heaters have cooled down.

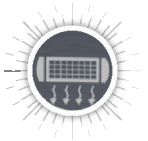

Allow at least 10 min. for heaters to cool.

close umbrella during consistent wind conditions that exceed 25mph.

# lights and heaters features and functions



## Emergency shut-down or interrupt Feature

Press the Power button on the control panel to shut-down or interrupt the operation of any function (Ambia LED lights and heaters). The red light on the Power button will turn OFF. The white lights on the heater icon and the light icon will turn OFF. Press the Power button to turn the umbrella back ON.



## Control panel indicator when the Umbrella is not level (tipped or tilted on an angle)

The Power button will be flashing in yellow when the umbrella is not level. All functions (Ambia LED lights and heaters) are inactive. The TUUCI logo is not backlit. When the umbrella is level and no longer tipped or tilted, it will return to a powered down state with the TUUCI logos backlit in white and all other functions OFF. Press the Power button to turn-on the umbrella. Then, turn-on the various functions.



## Lock-out unauthorized users from turning-on or -off various features of the Umbrella

There is a lock-out feature to prevent unauthorized user access. To turn-on the lock-out feature, press and hold the Power button for 5 seconds. All functions (Ambia LED lights and heaters) will maintain their original state of ON or OFF. The power button will be a solid yellow when the lock-out feature is activated.

To turn-off the lock-out feature, press and hold the Power button for 5 seconds. All functions (Ambia LED lights and heaters) will maintain their current state of ON or OFF. Users will have access again to turn ON-OFF the various functions.

If the Power button is pressed during a lock-out condition, activating the emergency shut-down or interrupt feature, the Ambia LED lights and heaters will be turned-off. All icon button lights will be OFF, except for the TUUCI logos.

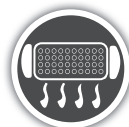

## Heater Automatic Turn Off Safety Feature

As a safety feature, the heaters on the Automated Umbrella will automatically turn off after 2 hours of operation. To turn the heaters back on, press the heater icon button.

## (2) Light Units, (4) Heaters Electrical Specs:

This dual canopy umbrella requires two electrical circuits (one circuit for each canopy side). Each circuit will consist of (1) light unit and (2) heaters, for a total of (2) light units and (4) heaters.

### Specifications for each circuit will be:

|                     |  |
|---------------------|--|
| Power Supply:       |  |
| Main Input Voltage: | 208-240VAC<br>50/60 Hz                     |
| Max. Amps:          | 13.7 A @220Volts AC<br>12.6 A @240Volts AC |
| Max. Watts:         | 3010 Watts                                 |

North America version:  
208-240V, 2 phases 60Hz (requires a minimum 15 Amp circuit)  
Umbrella comes with (2) 10ft Power Cords & Plugs. One for each circuit required.  
(Use with 20A - 250 Volts, NEMA 6-20R Receptacle compatible with NEMA 6-20P Plugs)

Europe version:  
220-240V, 1 phase 50Hz (requires a minimum 16 Amp circuit)  
Umbrella comes with (2) 10ft Power Cords & Plugs. One for each circuit required.  
(Use with 16A - 250 Volts, Schuko Receptacle compatible with Schuko 16A - 250 Volts Plugs)

Customer must connect to a protected power source circuit with proper Current Rating "Amps", near the umbrella, using an above ground Junction box, according to their local electrical codes and regulations.

## warnings & safety instructions

1. Read and understand entire owner's manual before assembling or operating umbrella.
2. Read and understand the warnings posted on the umbrella and/or components installed on the umbrella.
3. Disconnect electrical power to umbrella during inclement weather.
4. There is a risk of fire if heaters contact flammable materials or liquids.
5. Keep children away from power cords on or around umbrella.
6. Disconnect power before removing or servicing umbrella.
7. Allow sufficient cooling of heaters before closing umbrella.
8. Do not use this umbrella for other than its intended use.
9. Replace warning labels if they become obscured or removed.
10. Make sure the umbrella is properly electrically grounded.
11. Provide for adequate space to open and close umbrella without obstructions.
12. Customer's electrical power source connections if any, are to be installed / connected by a certified electrician. check local codes for guidance.
13. When closing / opening umbrella keep hands and face clear of all pinch points, or protruding umbrella components.

for frequently asked questions visit [tuuci.com/automationCL](http://tuuci.com/automationCL)

1005376

TUUCI frames are constructed from durable, marine-grade, weather-resistant materials including: fiberglass, armor-wall aluminum, Dura-TEAK composites, Aluma-TEAK aluminum and sustainable hardwood. All fasteners (nuts, bolts, pulleys, cam cleats, etc.) are marine-grade stainless steel and will withstand the most corrosive environments. Proper care and maintenance is important to extend the serviceable life of all TUUCI products. We recommend the following:

- Fresh water rinses once a week
- Weekly inspection of your TUUCI product is recommended. Loose screws should be tightened and any broken components replaced immediately to avoid further damage to your product.
- Prior to opening, ensure that the shade product is properly secured to an adequate shade anchor system.
- When opening a TUUCI parasol, separate each rib 10 inches from the center post, before raising the hub. Do not force hub if it does not rise easily.
- When closing the parasol, pull the fabric out from between the struts to avoid pinching or damaging the TUFF-SKIN canopy membrane.
- TUUCI recommends that all collapsible shade equipment be closed in wind conditions that exceed 25 MPH.
- Clean above-ground parasol bases regularly to maintain appearance. To clean, gently wash with soap and water using a nonabrasive cloth or pad.
- Check bolts in security stem regularly to ensure that they remain fully tightened.
- Do not roll Aluma-crete (Aluminum Shell, Concrete Filled) bases on their side as damage to shell or finish can occur.
- Do not use on stairways or over distances that exceed 50 feet, as damage to welded wheel tray may occur.
- Canopy should be cleaned regularly and can be cleaned without being removed from the frame. Hose down and clean with a mild soap and lukewarm water (no more than 100° F) using a soft bristle brush. Rinse thoroughly to remove soap. Allow fabric to air dry.
- Do not use a pressure washer to clean canopies.