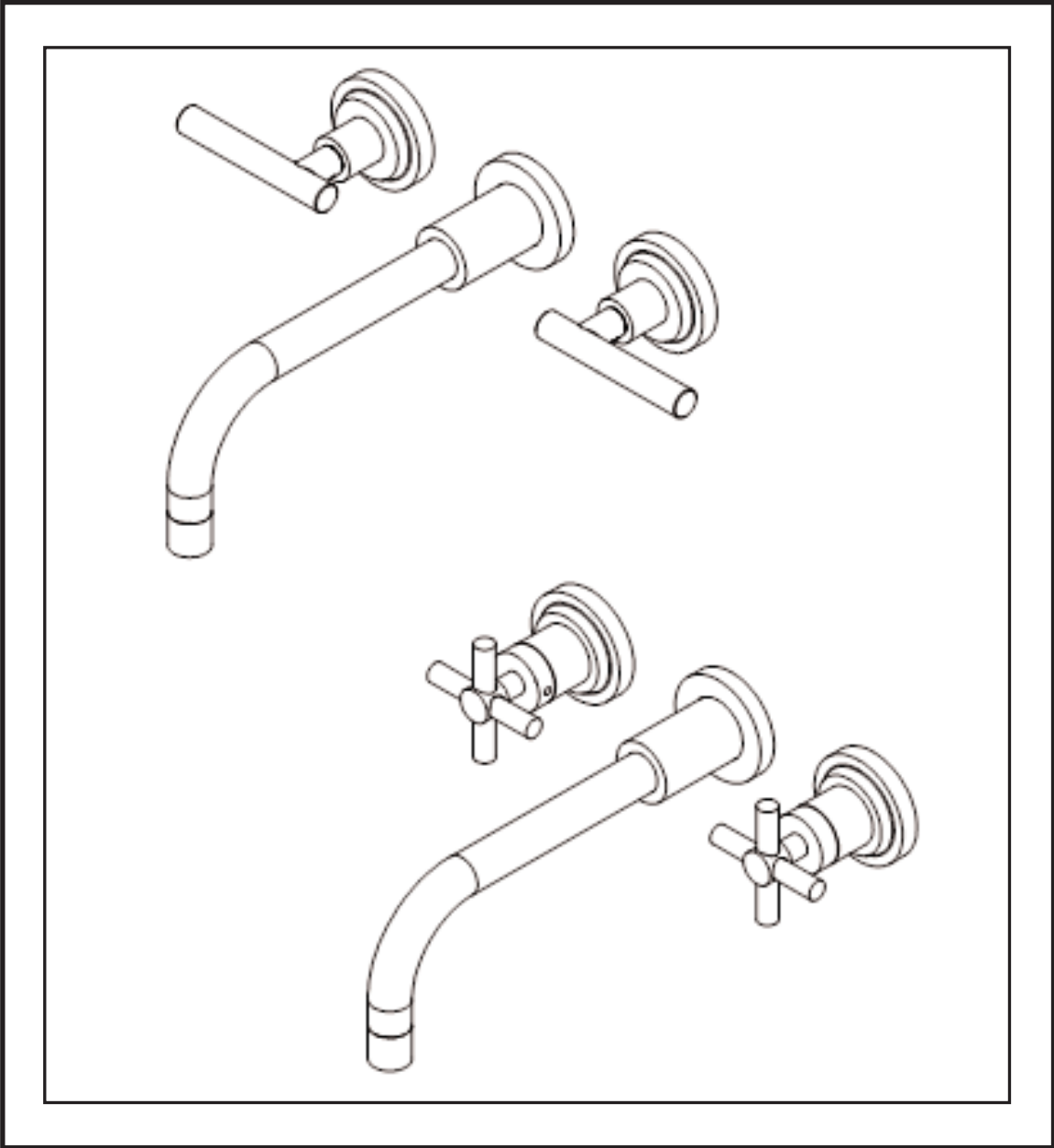




# INSTALLATION INSTRUCTIONS



**MODEL: SPRITZ**

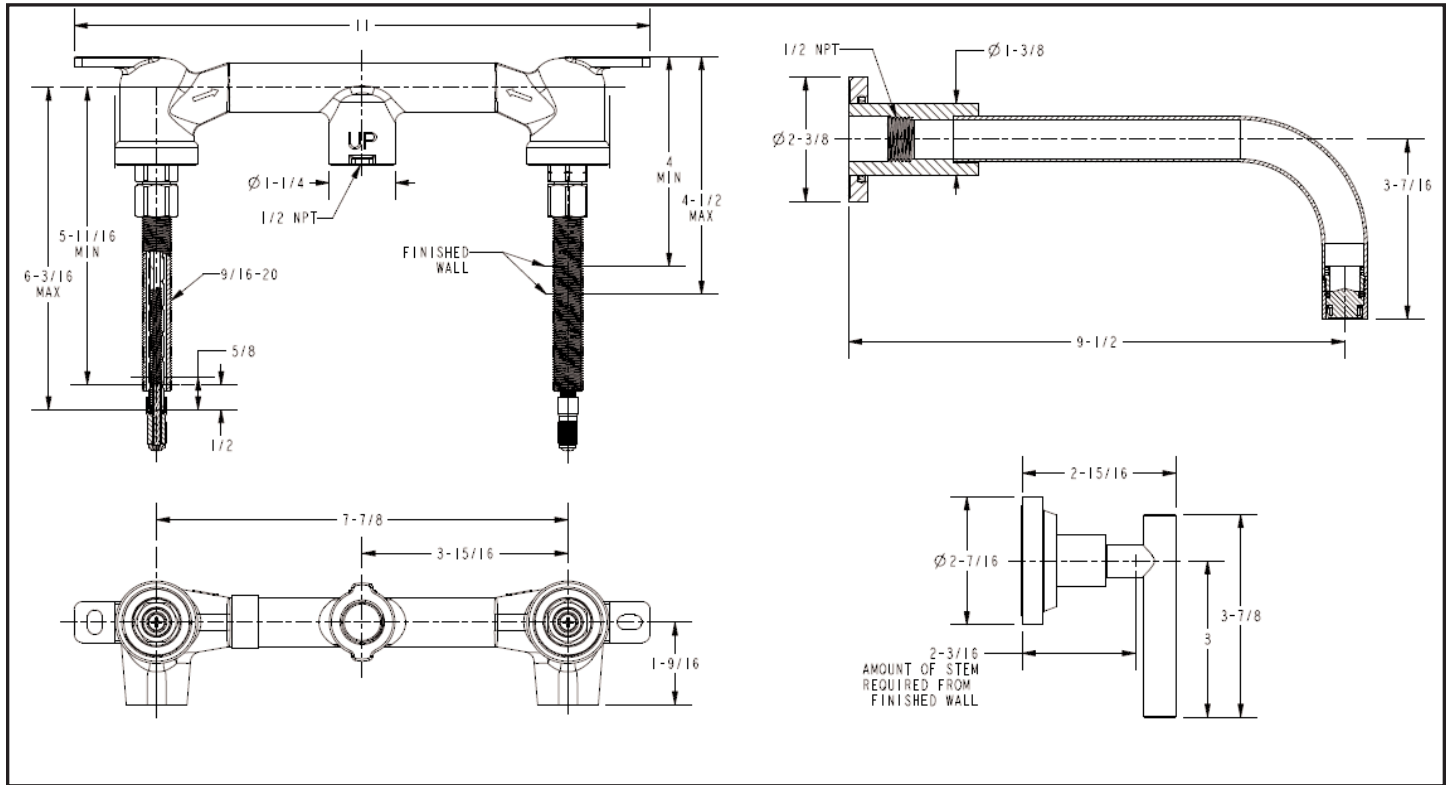
23670025 (RH-5610)

23520106 (RH-5610X)

10040081 (RH-5611)

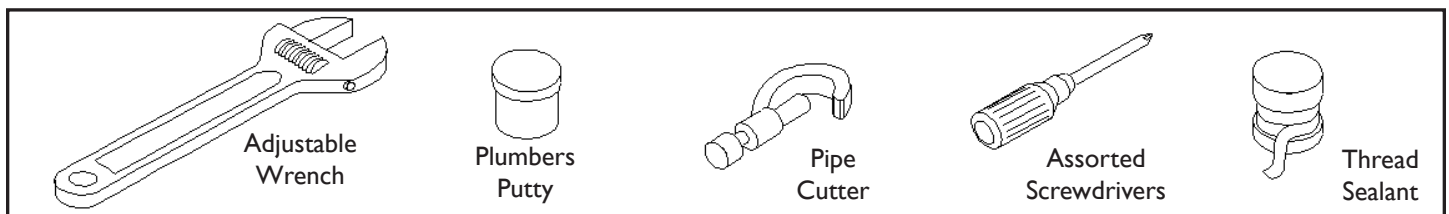
# Restoration Hardware Faucet Product Size Specification Diagram

**Note:** This valve is designed to fit in a 2" X 4" stud wall (or thicker) installation. Use stem extension kit #RH-I-384 (sold separately) if valve installed is too far away from finished wall).



Dimensions are in Inches and Approximation of a Typical Installation

## Common tools needed:



### We Recommend Installation by a Professional Plumbing Contractor

**Note:** Use plumber's tape or equivalent to seal all threaded port joints.

**Warning:** To prevent severe damage to valve body, any solder/braze process must be performed a min. of 4" from ports.

**Important: REMOVE CARTRIDGE FROM VALVE BODY (1) PRIOR TO APPLYING ANY HEAT/FLAME.**

**Note:** If cartridges are removed during installation, re-torque to factory specification of 14-16 ft-lbs

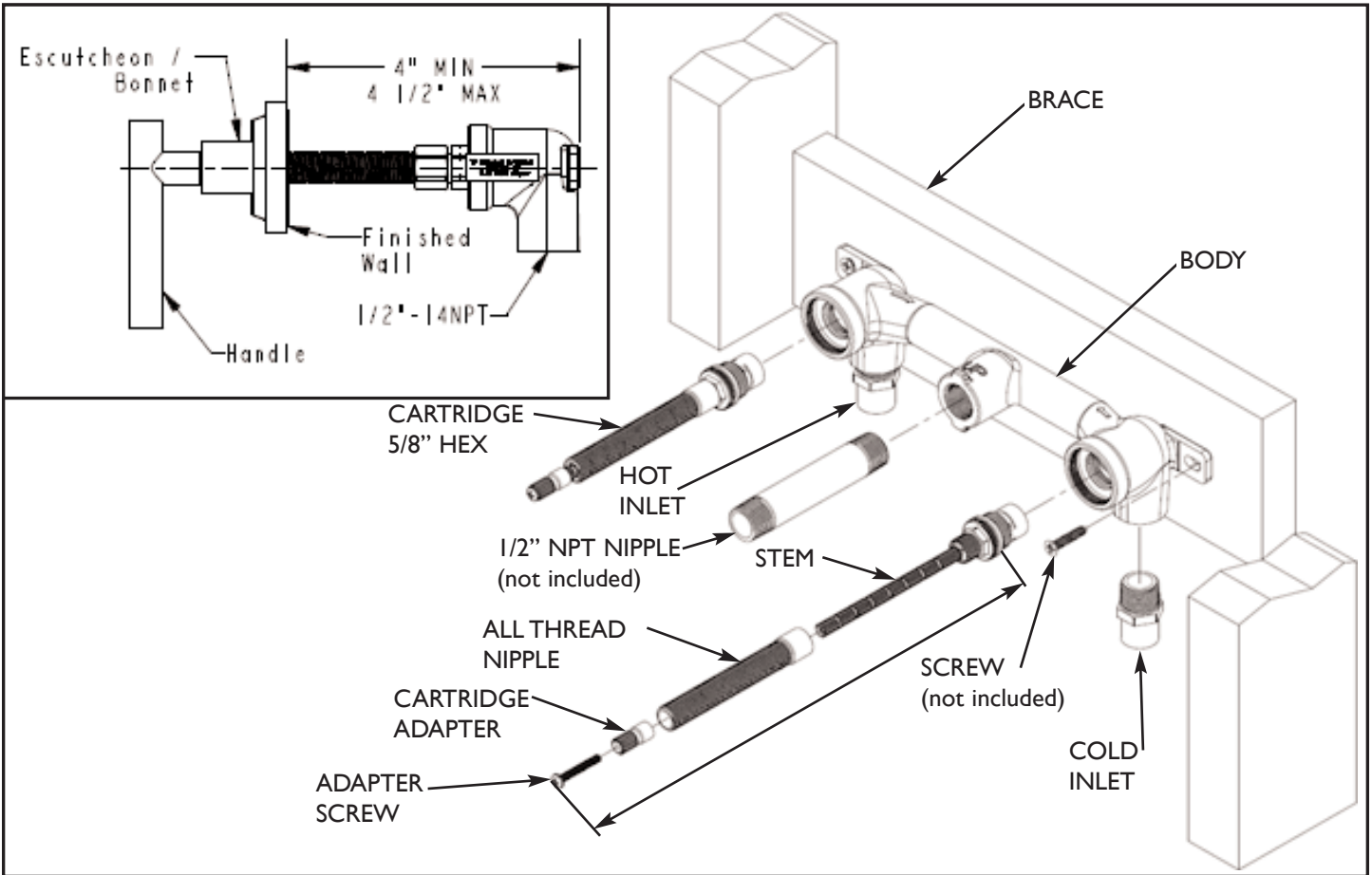
# I. Valve Installation

- Position valve BODY 4" – 4 1/2" from back side of valve BODY to finished wall surface as shown in **Fig. 1** and **Fig. 2** below.
- Secure valve BODY to cross BRACE using suitable SCREW, not included.
- Check the horizontal and vertical level of valve BODY by placing bubble level on STEMS. Also, ensure STEMS perpendicular to the finished wall. Make any necessary adjustments.
- Utilizing 1/2" copper supply pipe and 1/2" Socket End x 1/2"NPT Male Pipe Adapters to sweat water supply line to inlets of valve BODY, (blue STEM is cold, red STEM is hot). If sweating has to be done within 4" from valve inlets, remove cartridges during this process.

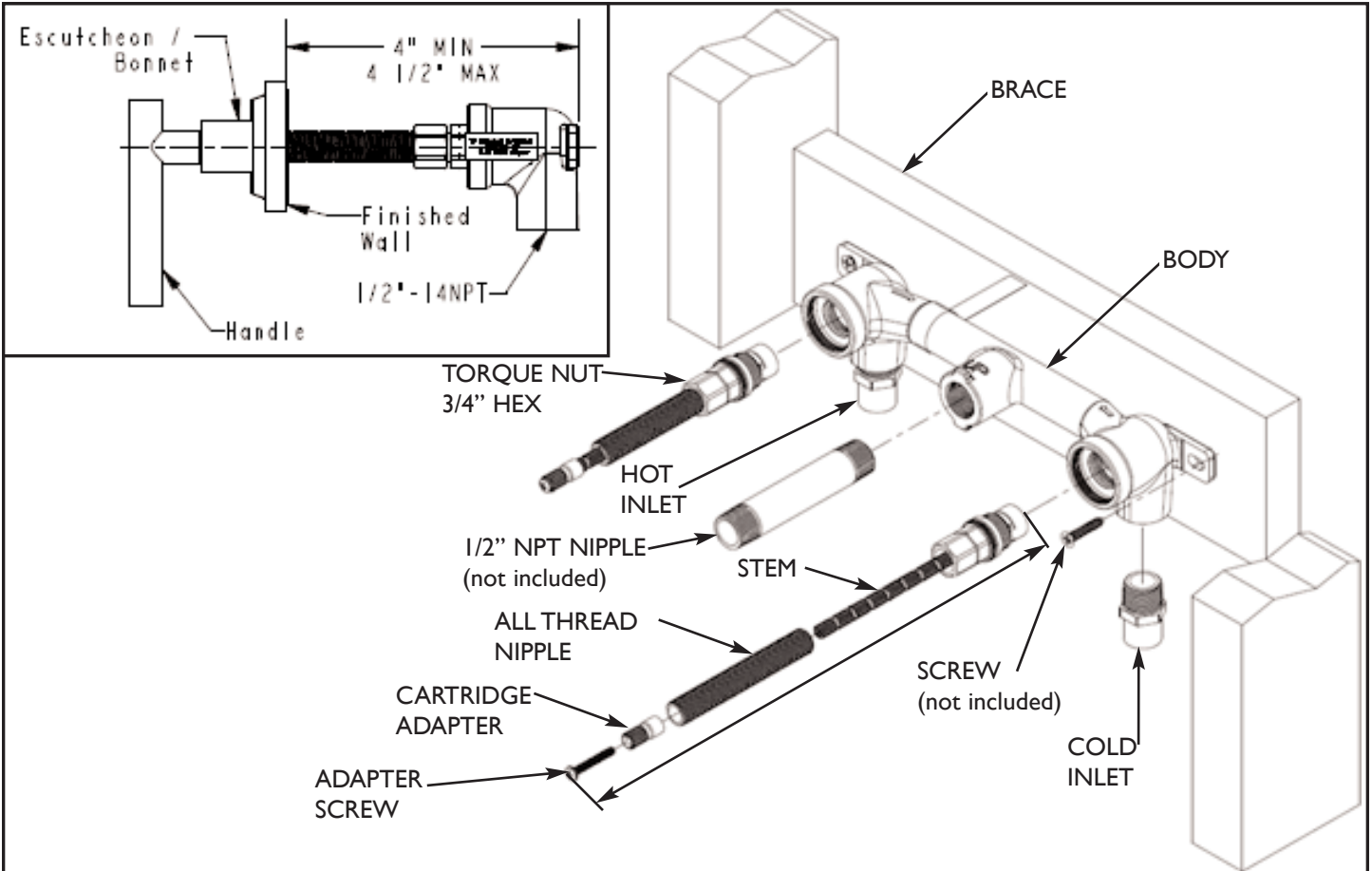
**Note: If cartridges are removed during installation, re-torque to factory specification of 14-16 ft-lbs.**

- **FOR MODEL with TORQUE-ABLE VALVE ONLY.** Use lever handle from Wall Mount Lavatory Trim to adjust stiffness of stem rotation by tightening or loosening TORQUE NUT (shown in **Fig. 2**). Check stiffness by placing lever handle in horizontal position onto cartridge STEM. Handle should not rotate under its own weight. (Note: Water supply to valve should still be off; water pressure may affect the stiffness of stem.)
- With STEMS in closed position, turn on water supply, pressurize system and check for leaks. Next, position a bucket in front of valve outlet, use pliers to slowly open the hot first and then cold valve. This is to flush out any debris and check for any blockage within the valve. Allow the water to flow for at least one minute. Close the valves and carefully inspect for leaks, with the water pressure on. Repair as needed.
- Installation for valve is now completed. Proceed to complete finished wall surface. (**Important:** openings of the finished wall around the cartridges has to be round diameter between 1 1/8– 1 1/4" and concentric with cartridge STEM to ensure enough clearance in case cartridge has to be removed for future service.)

**Fig. 1: For Wall Lav with Non-Torque-able Valve**

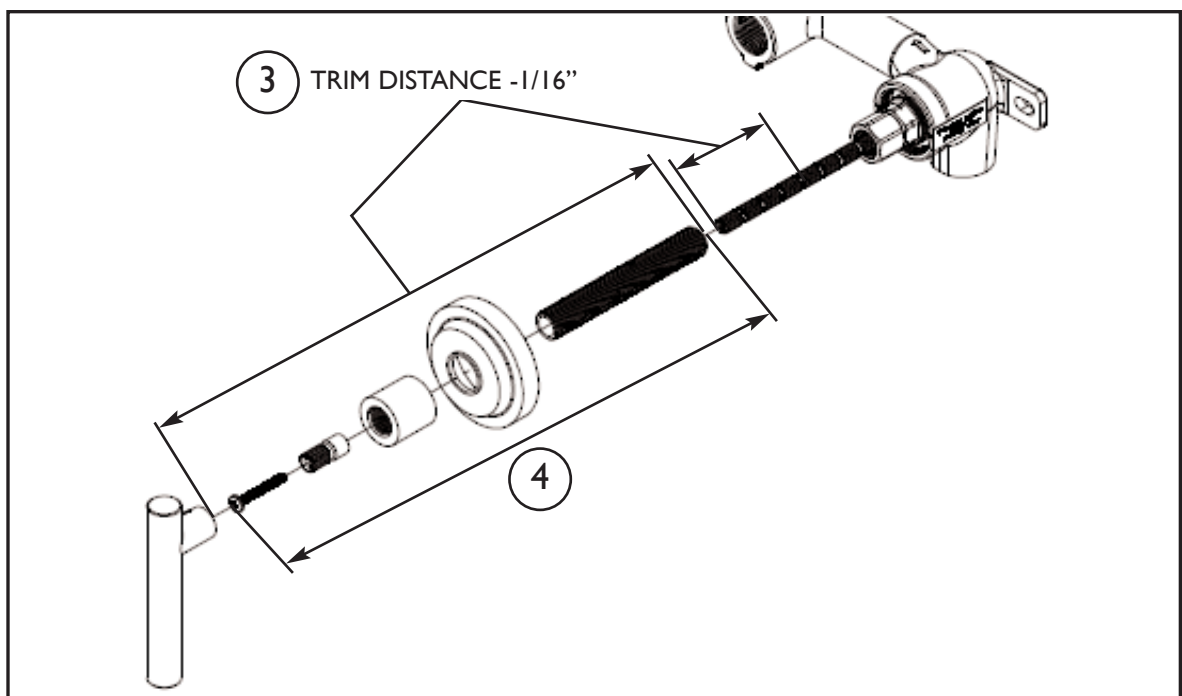
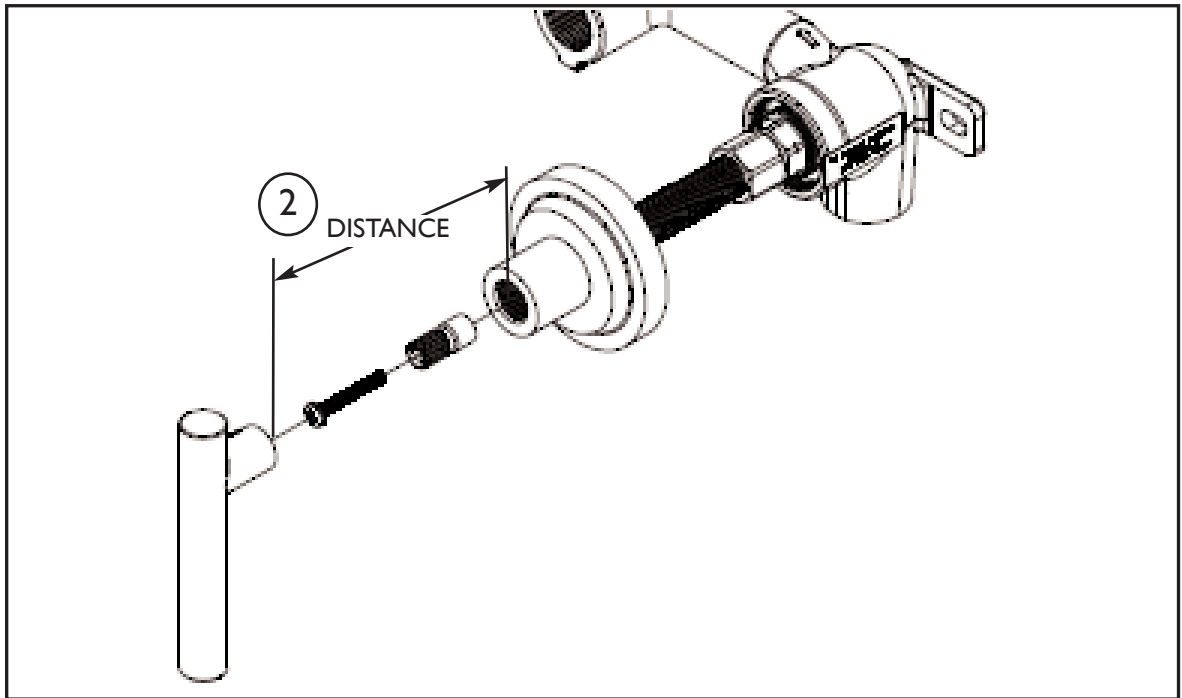


**Fig. 2: For Wall Lav with Torque-able Valve**



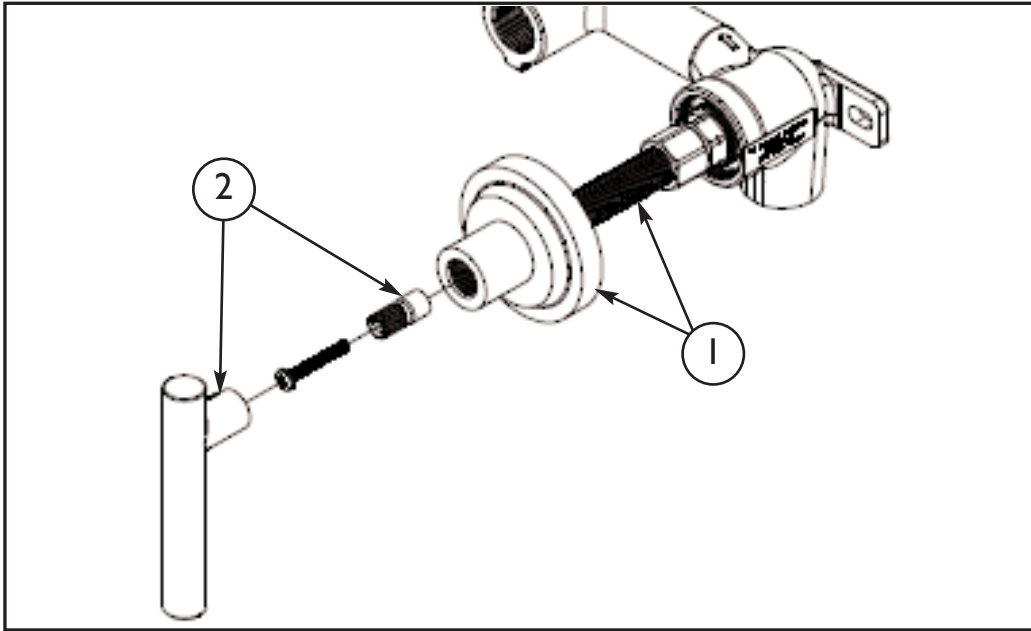
## 2. Trim Installation

1. Install ESCUTCHEON/BONNET and BASE RING trim pieces onto CARTRIDGE ALL-THREAD NIPPLE flush against finished Wall. Mark the CARTRIDGE ALL-THREAD NIPPLE where excess needs to be trimmed.
2. Remove the ADAPTER SCREW, temporarily install handle onto adapter and measure distance between top of escutcheon and base of handle.
3. Add 1/16" to the measured distance in the previous step.
4. Disassemble components again to trim the sum (sum = step 2 distance - 1/16") from the 20 tooth cartridge stem length.

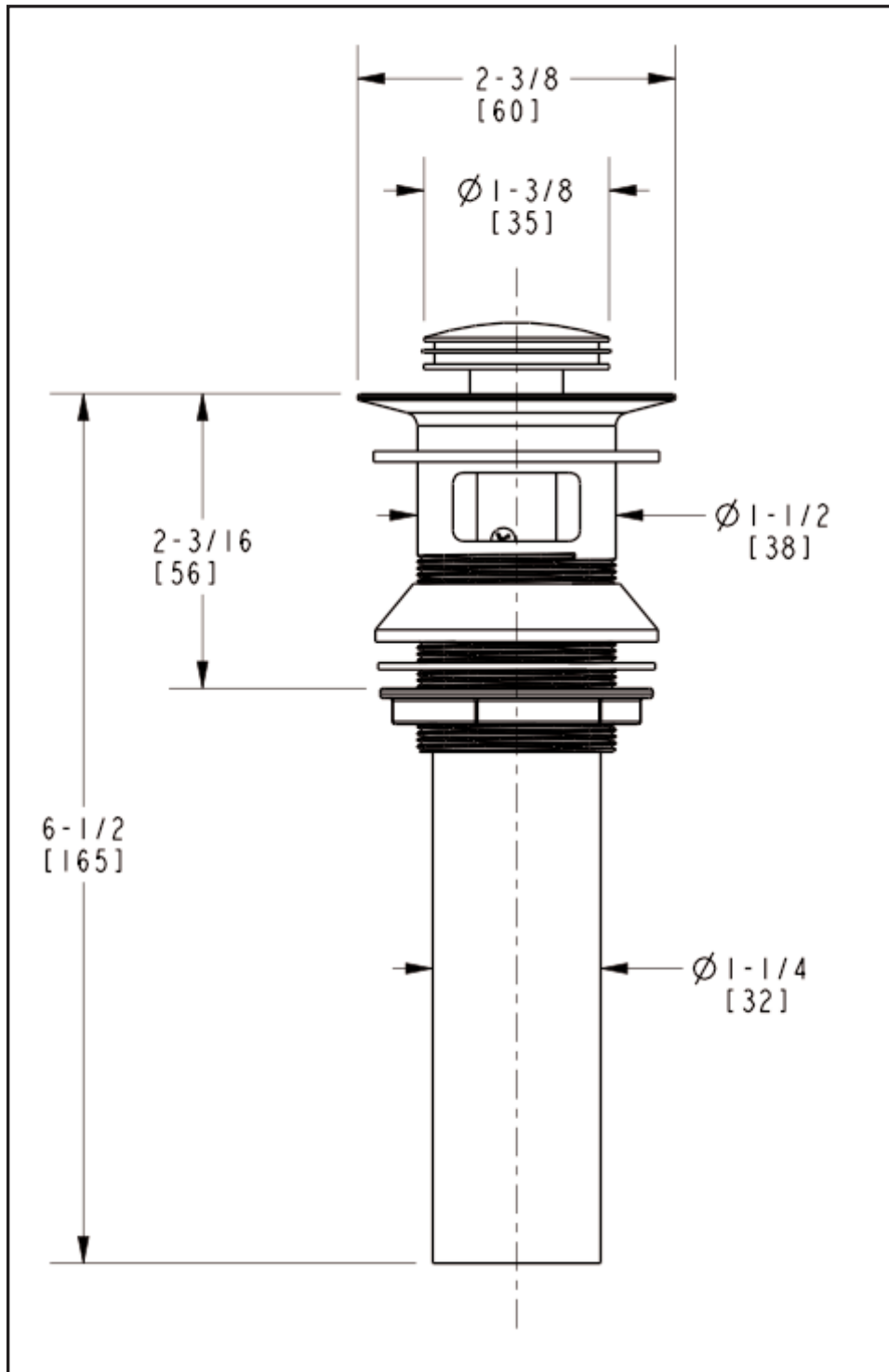


# 3. Handle Adjustment

1. Re-Install all thread nipple, base ring & escutcheon onto newly trimmed cartridge.
2. Place adapter and handle onto cartridge. Check alignment. As required, remove handle and rotate adapter 1 tooth clockwise (18 degrees), and recheck alignment. Repeat until handle is aligned.



# Restoration Hardware Lavatory Drain Specification Diagram



Dimensions are in Inches and Approximation of a Typical Installation

- Do not remove drain PLUG (1) from FLANGE (2). Place FLANGE (2) and white WASHER (3) through sink drain opening. (Clear silicone may be used in place of white washer.) From bottom side of sink, place cone shaped rubber WASHER (4) onto FLANGE (2) and slide up against sink bottom. Note: Cone portion of WASHER (4) to face upward. Next slide on clear flat WASHER (5) and secure with flange NUT (6). Assemble O\_RING (7) to TAILPIECE (8) and attach to drain FLANGE (2). Attach TAILPIECE (8) to p-trap drain (9) (not included). See Figure 1.

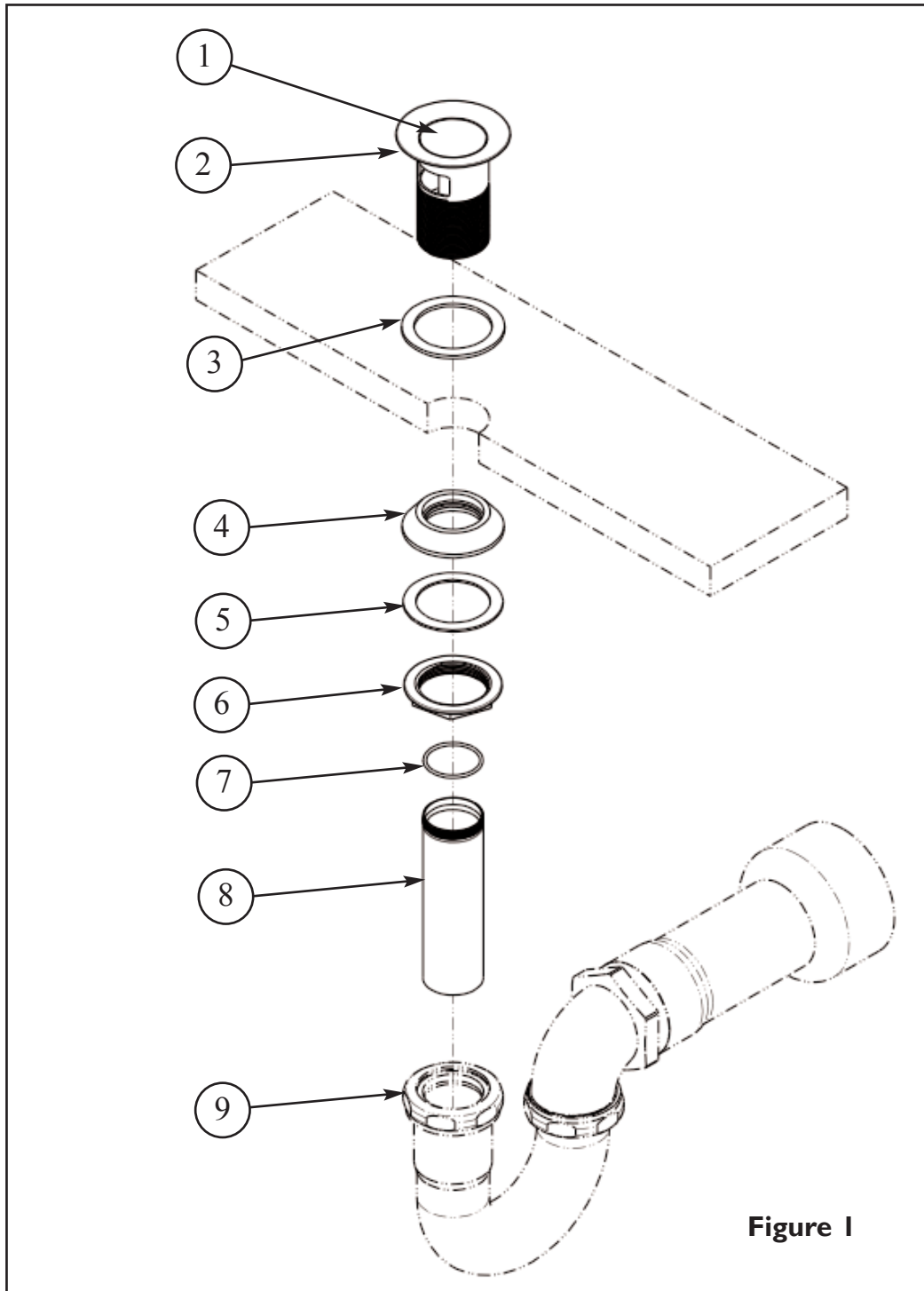


Figure 1



## Care and Cleaning

The lustrous finish on your Restoration Hardware Bathware fixture should be treated with care. Improper handling or cleaning can damage the surface of any metal finish. Use a soft cloth to wipe clean. Avoid harsh abrasive cleaner. Water contains lime and other mineral deposits that will be left on the surface after the water has evaporated. You can prevent these deposits from forming by always wiping the fixture dry immediately after use.

## Technical Support and Customer Service

For technical support in the installation of your Restoration Hardware Bathware fixture, please call 1-866-417-5207 weekdays between the hours of 7:00am and 4:00pm PST.

For other questions regarding your order, to order additional components of the Restoration Hardware Bathware Collection, to order replacement parts, or to address warranty issues, please contact Restoration Hardware Customer Service at 1-877-747-4671.