

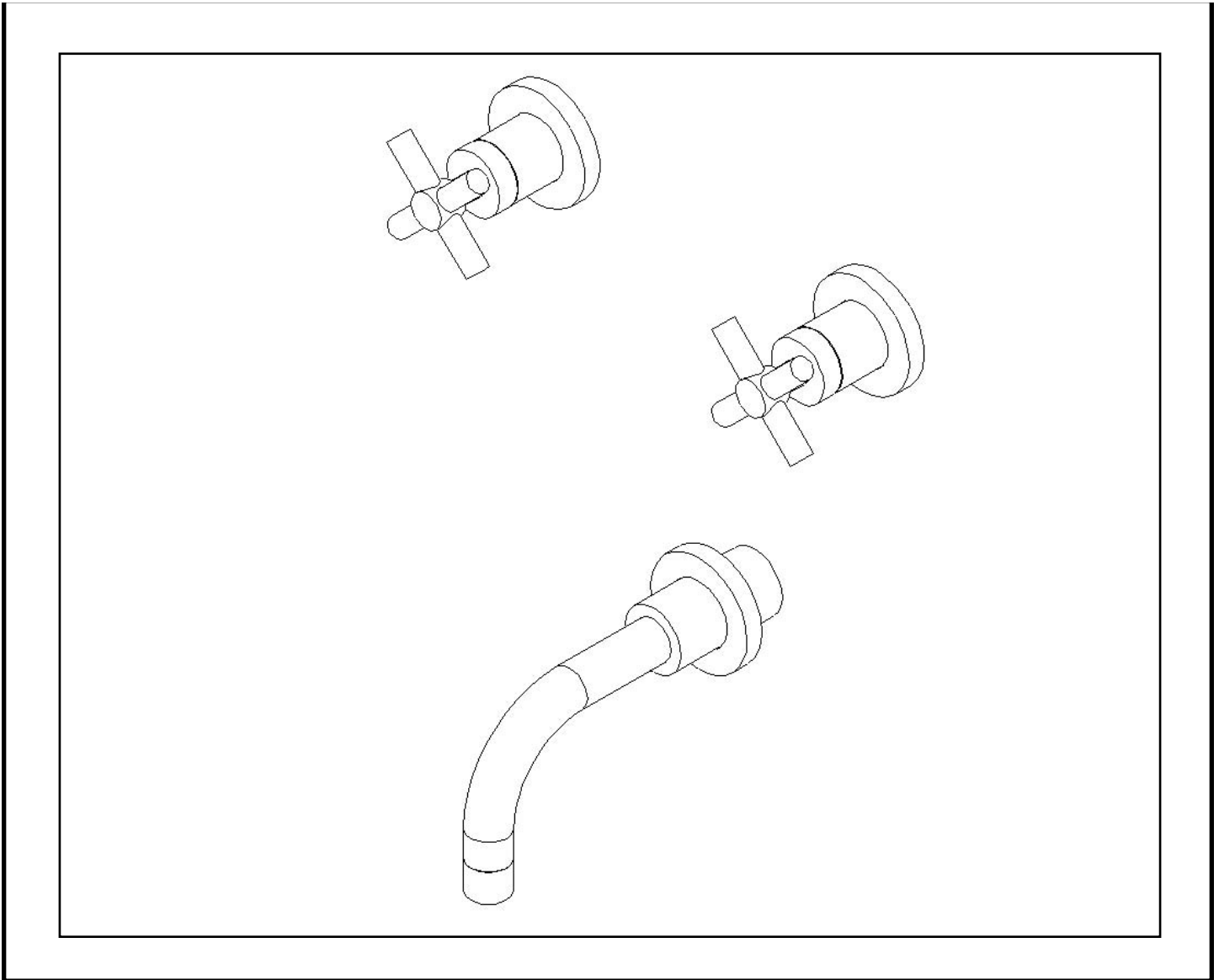

## Tub Set

# INSTALLATION INSTRUCTIONS



MODEL: SUTTON  
(RH-6450)

# Restoration Hardware Product Size Specification

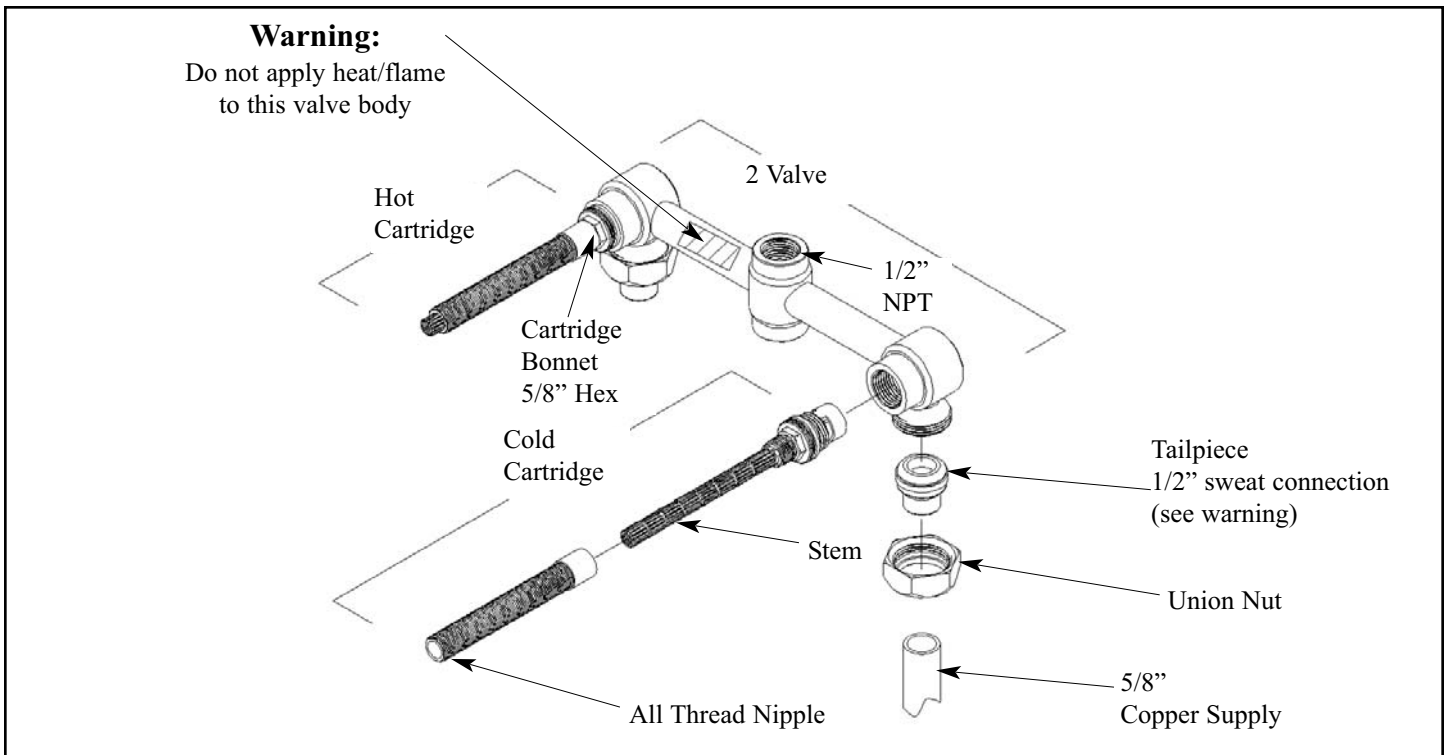
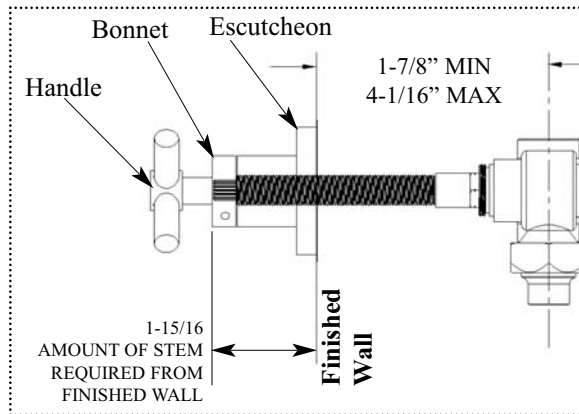
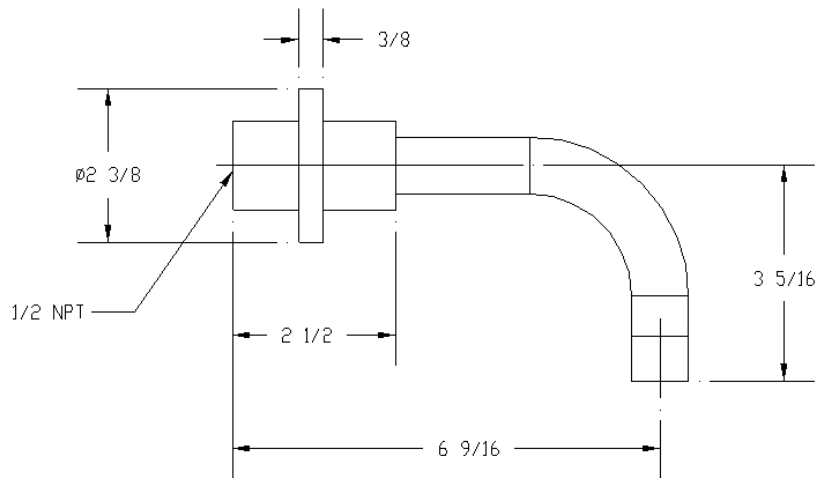

All thread connections are  $1/2$  inch NPT

Dimensions are in inches and Approximation of a typical installation

## Recommended Installation by a Professional Plumbing Contractor

**Note:** Use Teflon tape or equivalent to seal all threaded port joints.

**Warning:** To prevent severe damage to valve body, any solder/braze process must be performed a min. of 4" from ports.

- Turn off water to valve.
- Plug the unused ½" NPT outlet, top for tub, bottom for shower, with ½" NPT plug (not included).
- Slide union nuts onto copper supply pipes and solder/braze union tailpieces onto copper supply pipes.
- Tighten union nuts onto valve body. Check the level of valve body assembly.
- Connect end device line to the open ½" NPT outlet port.
- Turn on water supply, pressurize system and check for leaks.
- Trim stem to 1-15/16 from finished wall.
- All-thread needs to be trimmed 1/2" shorter than stem.

**Note:** Do not cut stem and all-thread nipple until finished wall is complete and a dimension check of handle and escutcheons/bonnet trim is done. (Stem is grooved at ½" intervals.)

- Install escutcheon/bonnet trim and handle.
- Secure handle into place by tightening handle setscrew.

**Note:** To achieve desired handle rotational alignment, the cartridge **MUST** be tightened in a clockwise rotation only. (Cartridge Bonnet factory torque is 14 ft-lbs.)

## Care and Cleaning

The lustrous finish on your Restoration Hardware Bathware fixture should be treated with care. Improper handling or cleaning can damage the surface of any metal finish. Use a soft cloth to wipe clean. Avoid harsh abrasive cleaner. Water contains lime and other mineral deposits that will be left on the surface after the water has evaporated. You can prevent these deposits from forming by always wiping the fixture dry immediately after use.

## Technical Support and Customer Service

For technical support in the installation of your Restoration Hardware Bathware fixture, please call 1-866-417-5207 weekdays between the hours of 7:00am and 4:00pm PST.

For other questions regarding your order, to order additional components of the Restoration Hardware Bathware Collection, to order replacement parts, or to address warranty issues, please contact Restoration Hardware Customer Service at 1-877-747-4671.