

RESTORATION HARDWARE

Vintage Potting Bench

Assembly Instructions & Product Care

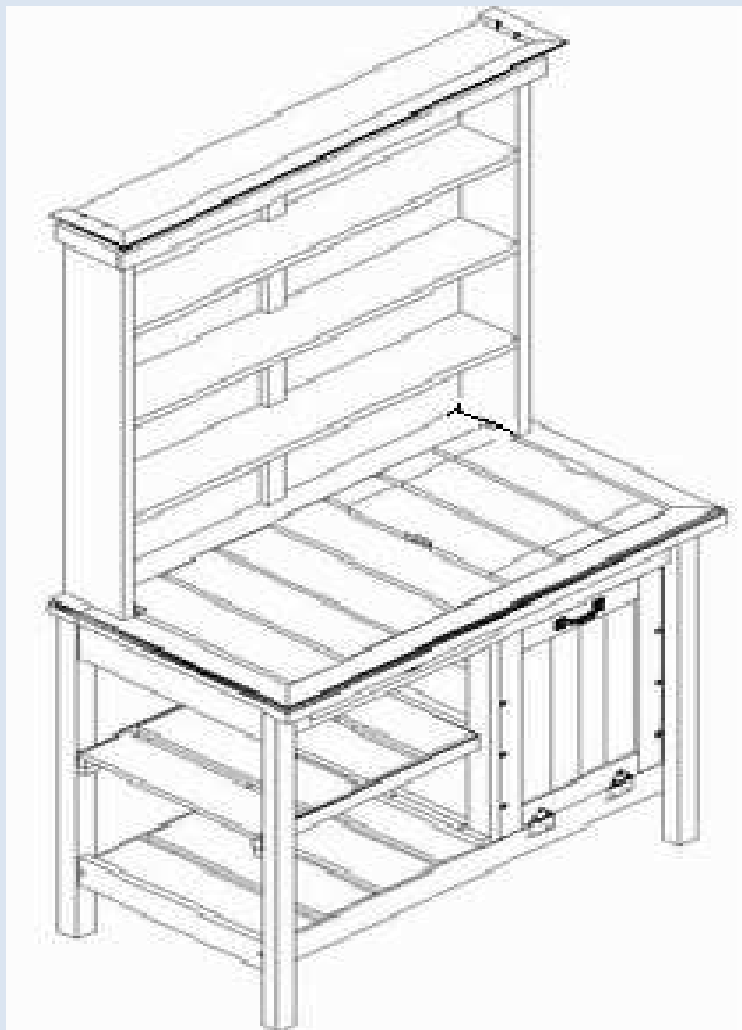

Parts & Hardware Included

Before Assembly, make sure you have all parts and hardware listed below. Unpack your new Vintage Potting Bench on a protected, level surface and identify the following components:

HARDWARE	PARTS
a: SMALL L BRACKETS 20x20	A: TOP VALANCE
b: SCREW 3.5X30	B: VALANCE ATTACHMENTS 2PCS
c: SCREW 3.0X18	C: FRONT VALANCE TRIM
d: MENDING PLATES	D: SHELVES 3PCS
e: LARGE L BRACKETS 40x27	E: SHELF SIDES 2PCS
f: BOLTS	F: CENTER BACK SUPPORT
g: CAM LOCKS	G: DRAWER FRONT
h: DOWELS	H: DRAWER SIDES 2PCS
i: HANDLES	I: DRAWER BACK
j: HINGES	J: DRAWER BOTTOM
K: WRENCH	K: TUB COVER
	L: TABLE UNIT
	M: LEFT SIDE LEGS
	N: RIGHT SIDE LEGS
	O: SHELF DIVIDER
*There may be additional pieces after assembly due to spare parts.	P: BOTTOM SHELF OF TABLE
	Q: MIDDLE SHELF OF TABLE
	R: TUB

<p>Step 1: Shelf Unit Assembly</p>	<p>Assemble VALANCE TRIM (part C) to VALANCE ATTACHMENTS (parts B) with hardware g. Attach SHELF SIDES (parts E) to SHELVES (parts D) with Hardware g and h; attach CENTER BACK SUPPORT (part F) to SHELVES (parts D) with Hardware b. Attach TOP VALANCE (part A) to assembled shelves and VALANCE ATTACHMENTS (parts B) with hardware g and h, secure with hardware a and c.</p>
<p>Step 2: Drawer Assembly</p>	<p>Fasten DRAWER SIDES (parts H) to DRAWER BACK (Part I) with Hardware b; Insert DRAWER BOTTOM (part J) into assembled parts (parts H, I); attach DRAWER FRONT (part G) to DRAWER SIDES (parts H) with Hardware g and h; Install Drawer Handle (Hardware i) to DRAWER FRONT (part G) using Hardware c. Install top half of Hinge (Hardware j) using hardware c.</p>
<p>Step 3: Leg panels Assembly</p>	<p>Attach SHELF DIVIDER (part O) onto BOTTOM SHELF OF TABLE (part P) with Hardware b; Attach SHELF DIVIDER (part O) to TABLE UNIT (part L) with hardware b. Attach RIGHT and LEFT SIDE LEGS (parts M & N) to BOTTOM SHELF OF TABLE (part P) and TABLE UNIT (part L) with Hardware h and f.</p>
<p>Step 4: Table Unit Assembly</p>	<p>Insert Assembled Drawer on to BOTTOM SHELF OF TABLE (part P); secure Hinges (hardware j) to BOTTOM SHELF OF TABLE (part P) with Hardware c. Install bottom shelf (part Q).</p>
<p>Step 5: Connect Shelf & Table</p>	<p>Install hardware h into assembled table unit, put assembled shelf unit onto dowels. Secure with hardware d and c; secure with hardware g. If desired, secure with l brackets e and c. Attach handles (hardware i) to drawer front with hardware c. Insert tub (part R) into tabletop and cover with part K.</p>

Illustrated Steps

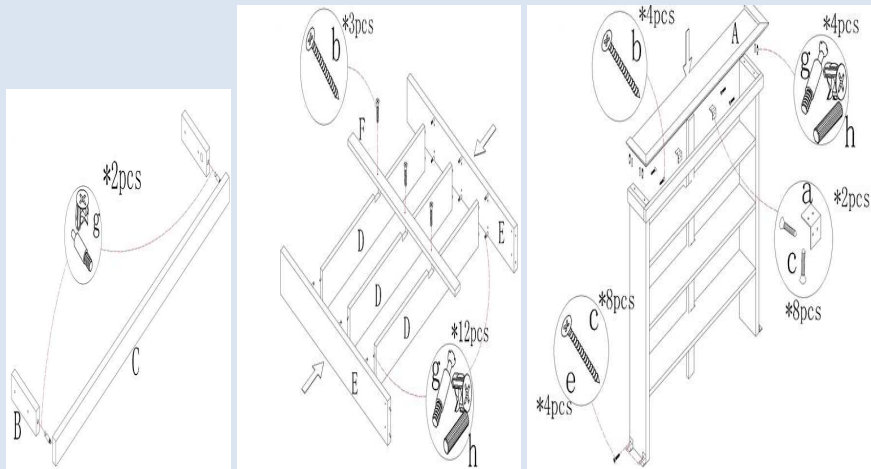

Step 1

Attach part C to part B with Hardware g (2 pcs);
 Attach parts D to parts E with Hardware h (12 pcs) and g (12 pcs);
 Attach part F to parts D with Hardware b (3 pcs);
 Attach assembled parts C and B with Hardware b (4 pcs);
 Attach part A to part B with hardware h (4 pcs) and g (4 pcs); secure with hardware a (2 pcs) and c (8 pcs).

**Optional, secure assembled shelving unit to assembled base with hardware c and e for more security if not leaning against a wall.

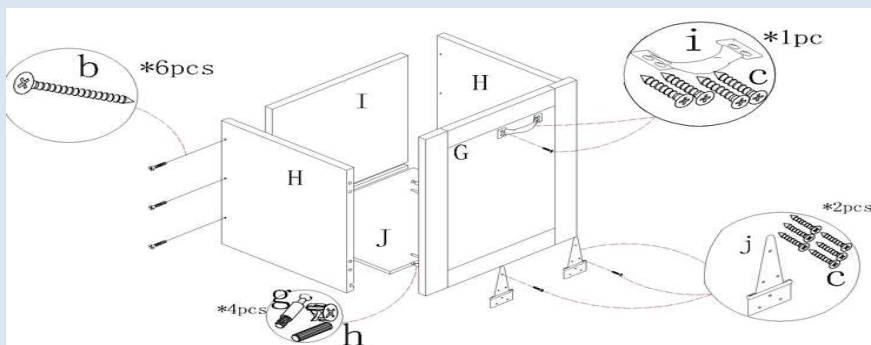

Step 2

Fasten parts H to part I with Hardware b (6 pcs);
 Insert part J into assembled parts H,I;
 Attach part G to parts H with Hardware g (4 pcs) and h (4 pcs);
 Install Hardware i (1 pc) to part G using hardware c (4 pcs)
 Install Hardware j (2 pcs) to part G using Hardware c (6 pcs).

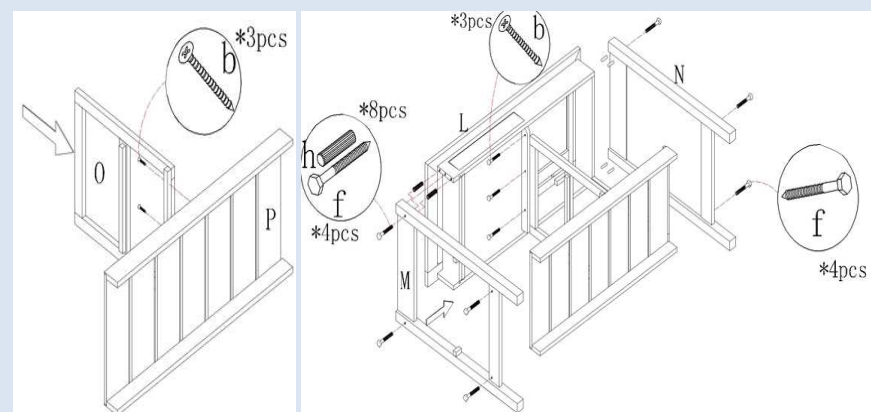

Step 3

Attach part P to part O with Hardware b (3 pcs);
 Attach part O to part L with Hardware b (3 pcs) *ensure oriented correctly;
 Attach M to assembled parts P and L with Hardware F (4 pcs);
 Attach N to assembled parts P and L with Hardware F (4 pcs).

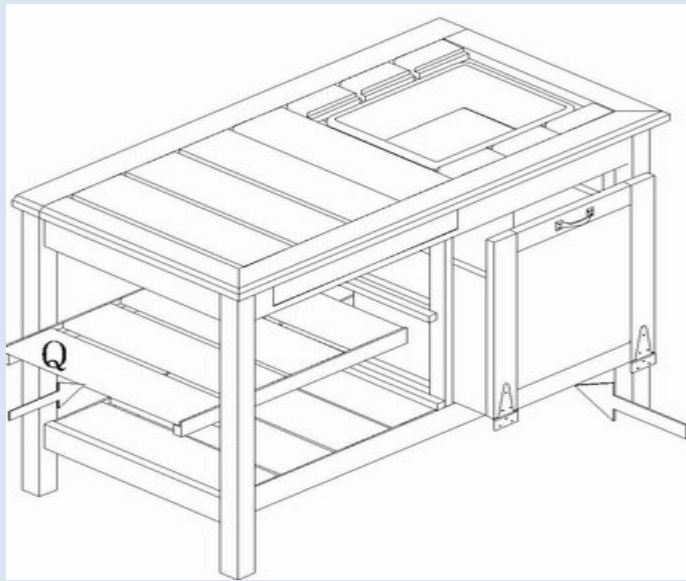

Step 4

Install part Q onto assembled parts L and P;
Insert the assembled box from Step 2 into assembled base and attach part j using Hardware c (6pcs).

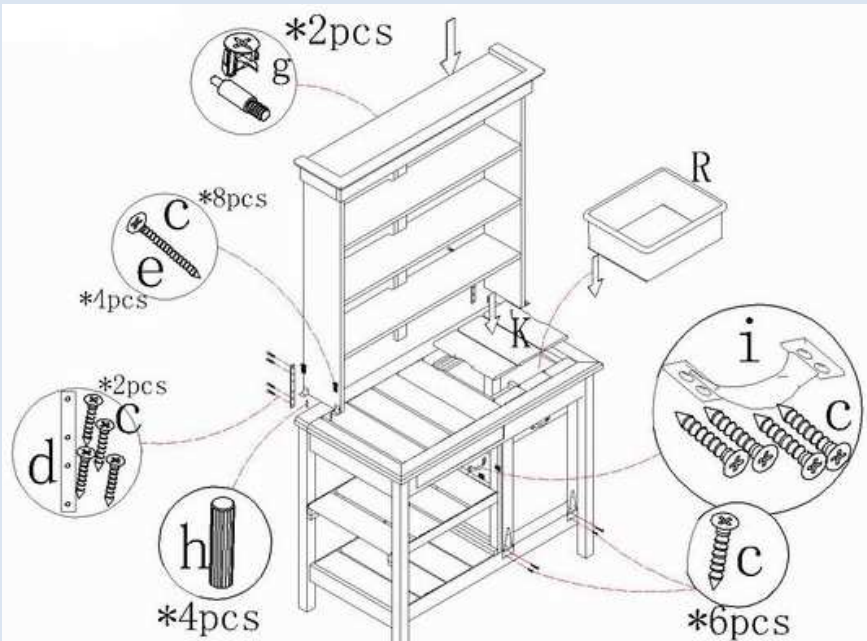

Step 5

Insert Hardware h (4pcs) into assembled shelf unit and put shelf unit on the back of table secure with hardware g (2pcs);

Attach on both sides with mending plates d (2pcs) with Hardware c (8pcs).

















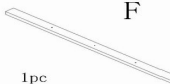
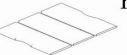
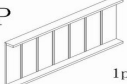



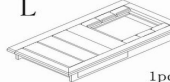

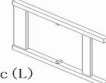
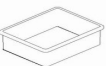

Attach Hardware i to drawer front using Hardware c (4pcs);
Install tub R and cover part K onto tabletop.

****Optional, if L brackets were used for extra security, secure with hardware c and e.**

Hardware and Parts

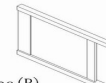
Assembly Instructions

1/3

a	 20x20	2pcs	A 	E 	J 	O 
b	 3.5x30	19pcs				
c	 3.0x18	52pcs	1pc	F 	K 	P 
d		2pcs				
e	 40x27	4pcs	B 	G 	L 	Q 
f	 M6x80	8pcs				
g	 15x12	24pcs	C 	H 	M 	R 
h	 8x30	32pcs				
i		2pcs	D 	I 	N 	1pc
j		2pcs				
k		1pc	3pcs	1pc	1pc (R)	

Caring for your Potting Bench

Your new potting bench is made of a sturdy, high quality hardwood. Its beauty comes from the texturized, vintage finish of the bench and the naturally occurring burs, butts and curls combined with the finish and stain colour give this piece its delightful rustic finish. As a result of this finish, no maintenance is required. Excessive dirt and debris can be swept off or washed with a cloth and warm water. No abrasive cleaners or chemicals should be used.