

Installation Instructions

3/4" STOP VALVE / VOLUME CONTROL

Model No. RH-5945



Recommended Installation by a Professional Plumbing Contractor

Note: Use Teflon tape or equivalent to seal all threaded port joints.

Warning: To prevent severe damage to valve, any solder/braze process must be performed a min. of 4" from ports.

These valves may be used as stop & volume controlling valves between water source and end output device. Typical usage is between thermo valve and multiple output devices (e.g. Showerhead, body sprays, handshowers, etc...).

Installing valve:

- Attach supply source to inlet of valve. Water flow direction is indicated by "ARROW" on side of body.
- Attach end device to outlet of valve.
- Position valve in wall as shown below. These dimensions are for typical installations. If thick finished wall materials are to be used in construction, it is recommended that valve is positioned toward outer face of stud.
- Support valve and/or piping to stud framing using strap tape or equivalent.
- Turn on water supply and inspect for leaks.

Installing Trim (after wall is finished):

- Remove all thread nipples from cartridge.
- Cut cartridge stem to 2-3/4" out from finished wall. (stem is grooved at 1/2" intervals).
- Cut all thread 1-1/2" shorter than cartridge stem. Reinstall all thread onto cartridge.
- Install trim and handle onto cartridge. Secure handle into place with screw.
- Press cap onto handle. Remove adhesive backing from button, align arrow and press into place.

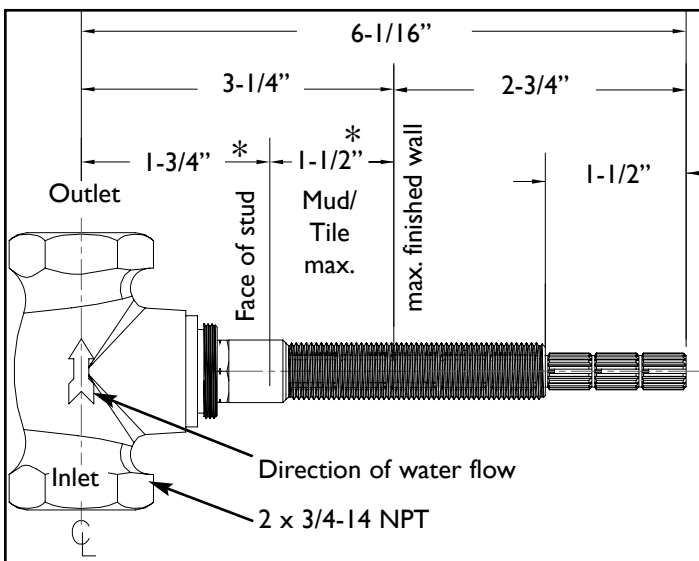
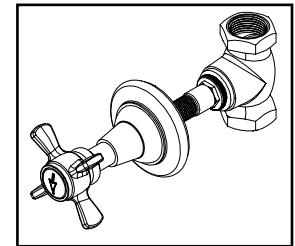

* If finished wall material is thicker than "Mud/ Tile max." stated, then the "Face of stud" dimension must be less than shown.

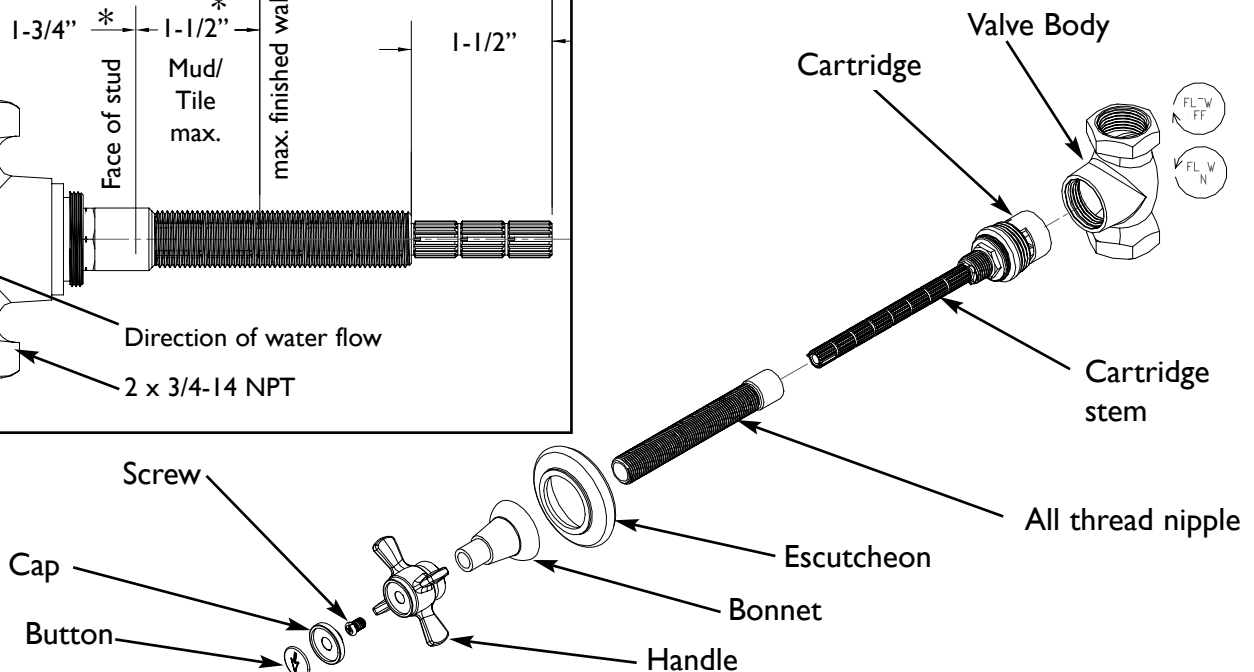

Care and Cleaning

The lustrous finish on your Restoration Hardware Bathware fixture should be treated with care. Improper handling or cleaning can damage the surface of any metal finish. Use a soft cloth to wipe clean. Avoid harsh abrasive cleaner. Water contains lime and other mineral deposits that will be left on the surface after the water has evaporated. You can prevent these deposits from forming by always wiping the fixture dry immediately after use.

Technical Support and Customer Service

For technical support in the installation of your Restoration Hardware Bathware fixture, please call 1-866-417-5207 weekdays between the hours of 7:00am and 4:00pm PST.

For other questions regarding your order, to order additional components of the Restoration Hardware Bathware Collection, to order replacement parts, or to address warranty issues, please contact Restoration Hardware Customer Service at 1-877-747-4671.