

# RH

RESTORATION HARDWARE

## INSTALLATION INSTRUCTIONS

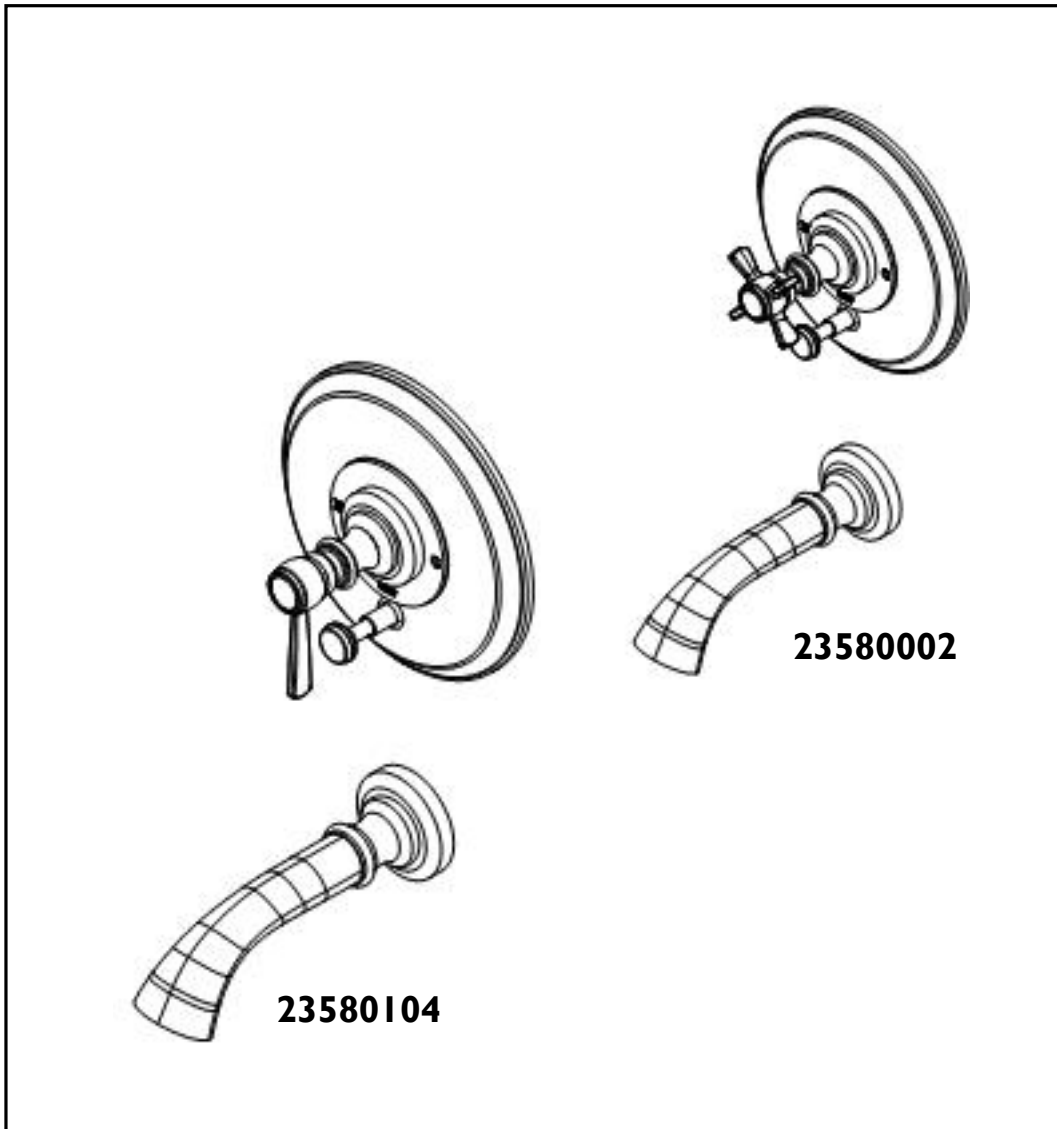

**MODEL: LUGARNO**

23580002 (RH-5920)

23580104 (RH-5920L)

# Restoration Hardware Balance Pressure Tub /Shower Set Specification Diagram

## SPECIFICATIONS

Min. Operating pressure: 20 psi [140 KPa]  
 Max. Operating pressure: 125 psi [860 KPa]  
 Max. Burst pressure: 500 psi [3450 KPa]  
 Max. Hot water temp: 110°F [40°C]

Flow rate in USGPM [l/min] @ 50 psi [345 KPa].

	Tub	Shower
ID Diverter (Automatic):	6.5 [25]	5.3 [20]

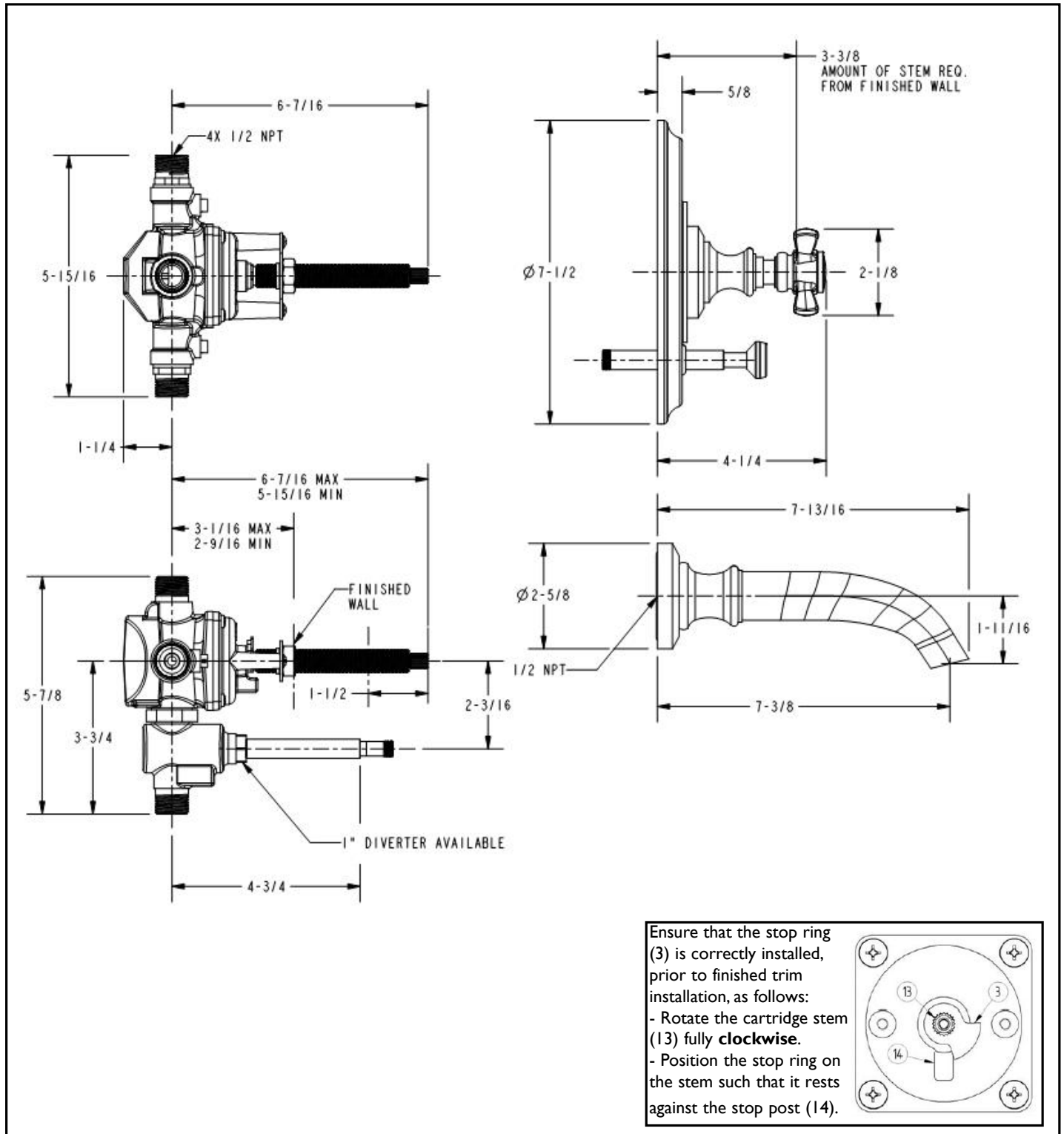

All Threaded Connections are 1/2" NPT

Dimensions are in Inches and Approximation of a Typical Installation

# Common tools needed:

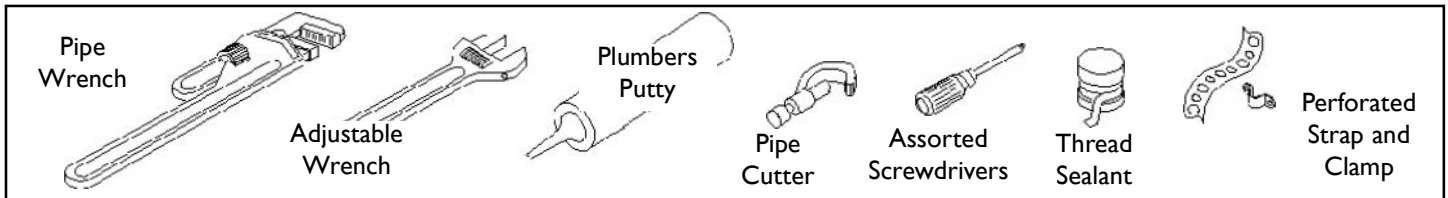

## Installation Instructions

We Recommend Installation by a Licensed Plumbing Professional

### I. Valve Assembly

- Position and locate VALVE (1) as shown in Figure 1 and Specification Diagram on page 2.
- Connect Hot (3) & Cold (2) water supply to 1/2 NPT side inlets.
- Apply thread sealant to the supply fittings and firmly tighten into VALVE (1) inlets. Under normal soldering conditions the removal of check valves and mixing cartridge is not necessary; however, if brazing and / or induction heating is used removal is required. Whenever possible, it is best to perform all solder/brazing operations on piping prior to attachment to VALVE (1).
- VALVE (1) and / or SUPPLY (2,3) must be secured to CROSS BRACE (4) using PERFORATED STRAP (5) or equivalent.
- Apply thread sealant to SHOWER RISER (6) and attach to VALVE (1) shower outlet port.
- Secure SHOWER RISER (6) to CROSS MEMBER (4) using PERFORATED STRAP (5) or equivalent.
- Apply thread sealant to TUB SUPPLY (7) and attach to VALVE (1) tub outlet port.
- Secure TUB SUPPLY (7) to CROSS MEMBER (4) using PERFORATED STRAP (5) or equivalent.
- Apply PLUG (8) for test. Turn on both water supplies to valve and check for leaks. Note: Water pressure **must** be applied to both hot and cold inlet ports for proper valve operation.
- Turn on water supply and check for leaks.
- After inspection turn off water supply.

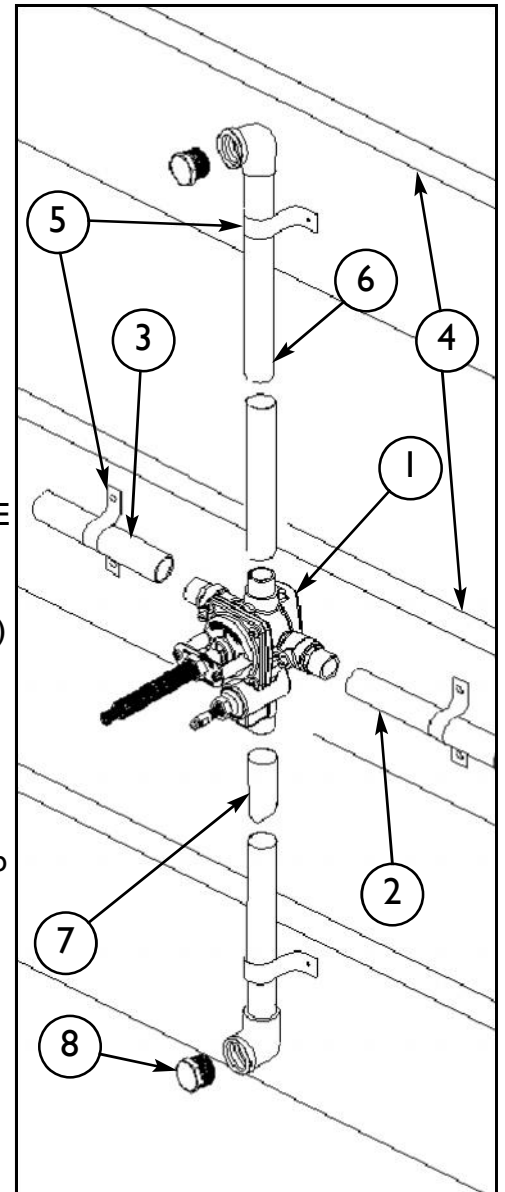

## 2. Setting The Temperature Limit Stop

- Remove the HEX NUT (8), all-thread NIPPLE (4), RETAINING SCREWS (5) RETAINING PLATE (3) and STEM (2) from the VALVE COVER.
- Remove the LIMIT STOP (6) see figure 2. Do not remove the MECHANICAL STOP (7). (If for any reason the MECHANICAL STOP (7) is removed refer to **Cartridge Removal and Replace** section below.) From the CLOSED position, rotate the CARTRIDGE STEM counter-clockwise until the desired temperature is achieved.
- Place the LIMIT STOP (6) on the CARTRIDGE STEM against the STOP BLOCK (10) located on VALVE COVER. Rotate the CARTRIDGE STEM several times to make sure the stop is at the desired temperature setting.
- Replace the STEM (2), RETAINING PLATE (3), RETAINING SCREWS (5) and all-thread NIPPLE(4) onto VALVE COVER. (NOTE: For stem to be fully seated into cartridge stem, all-thread nipple and Hex nut must be tightly secured against retaining plate.)
- Proceed to the VALVE TRIM INSTALLATION.

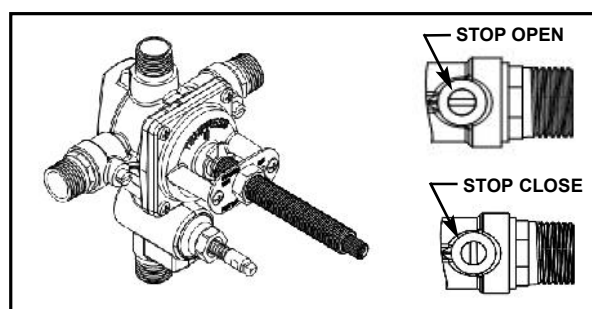
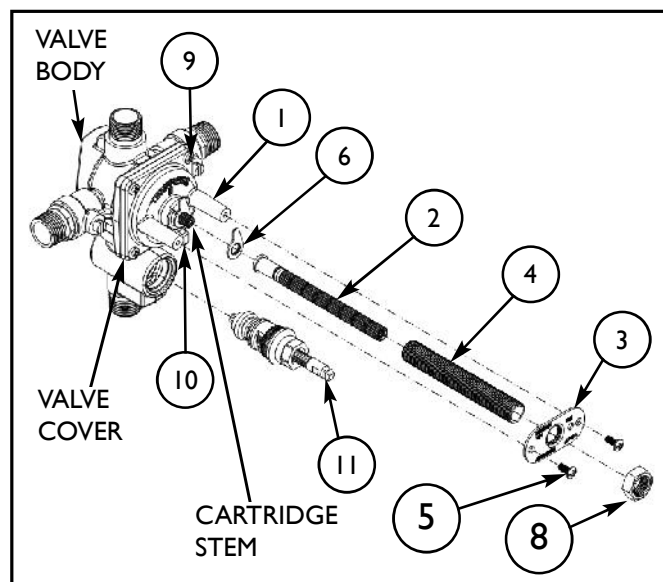

### 2a. Cartridge Removal And Replacement

- Remove the HEX NUT (8), all-thread NIPPLE (4), RETAINING SCREWS (5), RETAINING PLATE (3) and STEM (2) from the VALVE COVER.
  - Remove the LIMIT STOP (6) and MECHANICAL STOP (7) Remove the COVER SCREWS (9), VALVE COVER and cover O-RING (Not shown).
  - Carefully slide the CARTRIDGE STEM out of VALVE BODY. (If filter removal is necessary refer to **Cleaning the Filter** described in Trouble Shooting Section.)
  - Replace CARTRIDGE STEM ensuring that the cartridge's O-RINGS (Not shown) are in place and lubricated with plumbers (non-petroleum) grease. The "H" and "C" on the side of the CARTRIDGE STEM indicates the cartridges proper orientation to the appropriate inlet supply line.
  - Once the CARTRIDGE STEM is installed, it is very important to confirm that the cartridges front tabs are correctly locked into the VALVE BODY mating hole.
  - Replace the cover O-RING(Not shown), VALVE COVER and tighten COVER SCREWS (9) firmly into place.
  - To set the MECHANICAL STOP (7) rotate clockwise the CARTRIDGE STEM until it stops.
- Warning: Do not forcefully rotate stem closed.**
- Place the MECHANICAL STOP (7) onto CARTRIDGE STEM (10) as shown in figure 1.
  - Replace LIMIT STOP (6) as described above in **Setting the Temperature Limit Stop**.

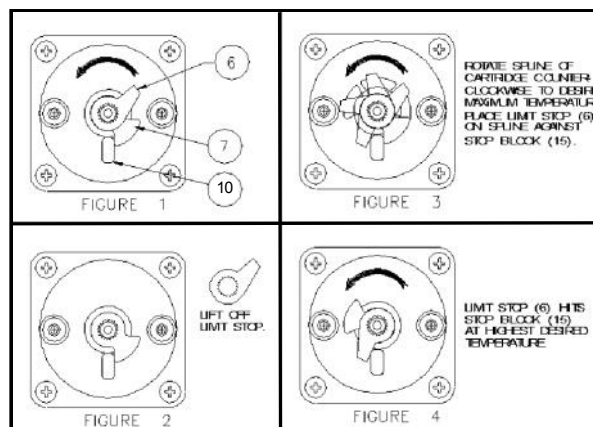

# 3. Valve Trim Installation

(Perform these steps after finished wall has been completed)

- The STEM (3) must be trimmed to 3 1/2" from finished wall. Remove STEM (3) by loosening NUT (2) and removing NIPPLE (1), NUT (2) and STEM (3). Trim STEM (3) to previously mentioned dimension.
- The NIPPLE (1) must be trimmed 1 1/2" less than STEM (3).
- Fasten STEM (3) and NIPPLE (1) onto VALVE (4). Use NUT (2) to lock NIPPLE (1) into place. Rotate STEM (3) to ensure there is no binding. If binding, loosen NIPPLE (1) until STEM (3) moves freely and does not wobble.
- Place diverter trim LINK (6) and POST (7) onto valve's DIVERTER(5).
- Tighten diverter trim SLEEVE (9) onto DIVERTER (5).
- Align cover PLATE (8) and slide onto valve NIPPLE (1) and diverter SLEEVE (9). (Soapy water will improve sliding of rubber seal onto diverter sleeve.)
- Place ESCUTCHEON (11) and BONNET (12) onto NIPPLE (1) and firmly tighten BONNET (12) in place to secure trim onto VALVE (4).
- Secure diverter KNOB (10) onto POST (7).
- Secure HANDLE (13) into place by tightening SCREW (14).
- Place CAP (15) onto HANDLE (13).
- Remove adhesive backing from BUTTON (16), align and press into CAP (15).

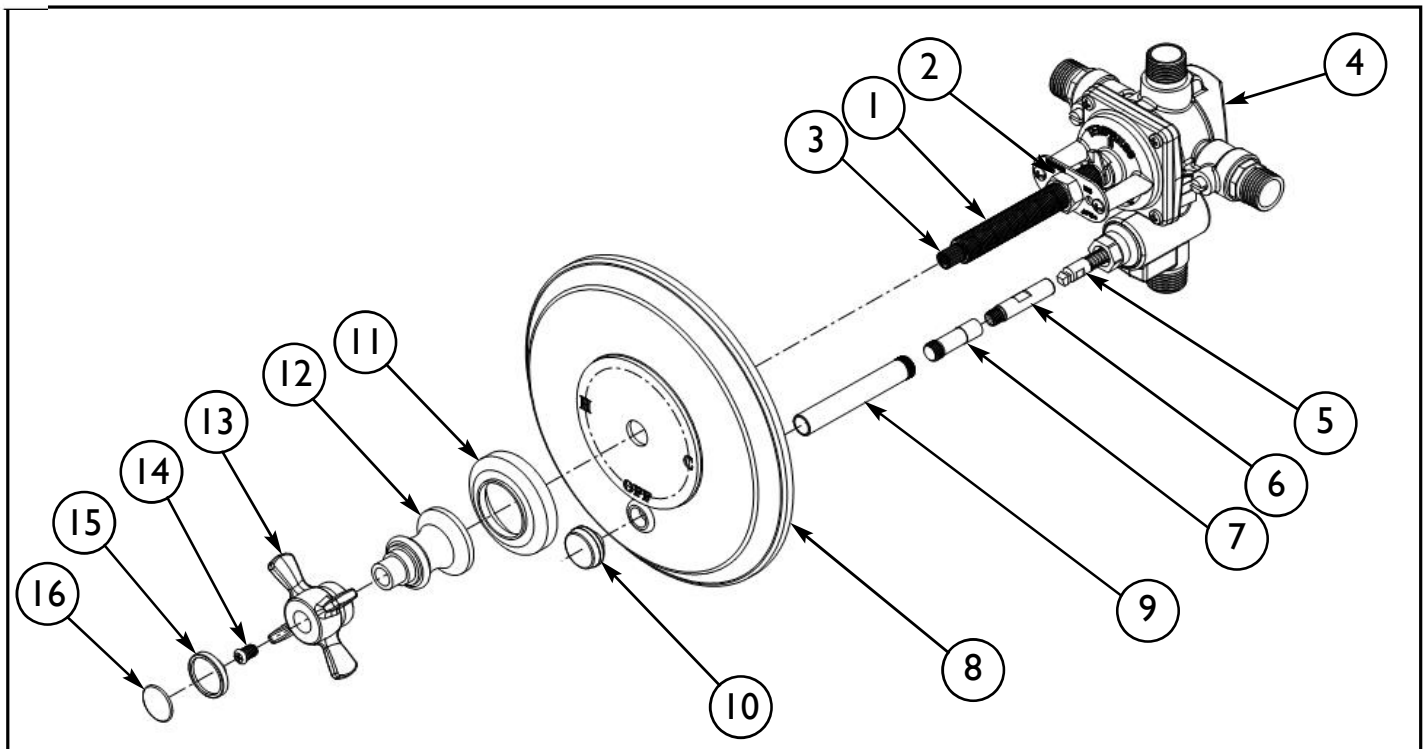

## 4. Tub Spout Installation

- Based on finished wall thickness select appropriate size 1/2" NPT NIPPLE (2) for SPOUT (1) installation.  
Note: NIPPLE (2) is not included.
- Apply thread sealant to both ends of NIPPLE (2) and thread into fitting inside finished wall.
- Attach SPOUT (1) to protruding NIPPLE (2) and secure into place.

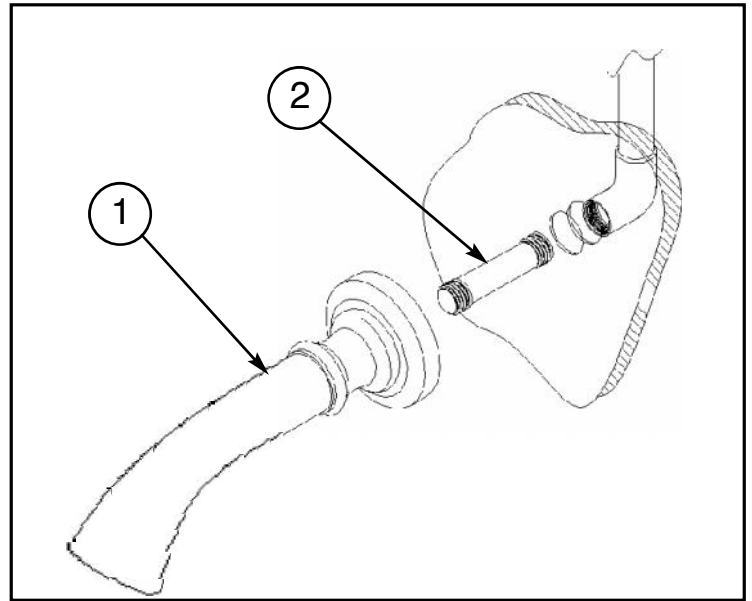

## 5. Showerhead Installation

For RH-5921, available in catalog and on web only,  
(Balanced pressure tub and shower with Speakman  
Ultra Showerhead kit.)

- Side SHOWERARM (2) through the FLANGE (3).
- Apply thread sealant to both ends of ARM (2) and thread into fitting inside finished wall.
- Turn on water supply, check for leaks and make any final adjustments required.
- Open valve and flush both shower and bath lines of debris.
- Side FLANGE (3) against wall.
- Attach SHOWERHEAD (1) to end of ARM (2).

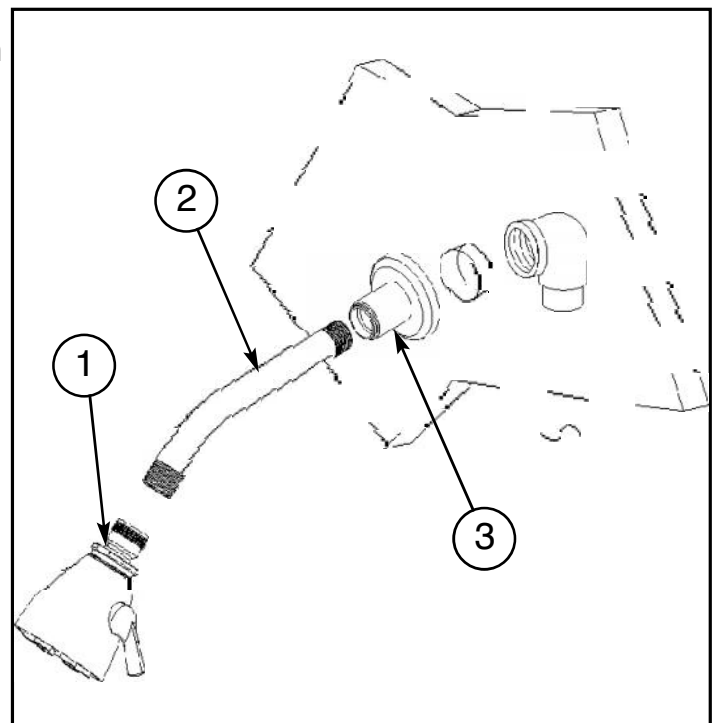

# 6. Test Installed Tub / Shower Set

- Turn on the shower valve by rotating the handle counter-clockwise. Water will start to flow from the tub spout.
- Pull the diverter knob to operate the showerhead.
- Water mixing temperature to handle rotation is as follows:  
 1/4 to 1/2 = warm                      1/2 to 3/4 = hot
  - 0 to 1/4 = cold    ● 1/4 to 1/2 = warm    ● 1/2 to 3/4 = hot

# 7. Troubleshooting

* <b>WARNING</b> - Never try to stop dripping by applying extreme force or overtightening the handle.		
<b>MALFUNCTION</b>	<b>CAUSE</b>	<b>REMEDY</b>
Opening immediately to hot water.	Hot and cold water supplies have been connected in reverse.	Rotate cartridge. (See Page 3)
Water drips after shutting off the valve.	Residual water in valve and piping.	Allow approximately 3-8 minutes to drain.*
	Incorrect setting of the mechanical stop against the stop block causing a partially opened cartridge.	Reset the mechanical stop. (See Page 3)
	O-ring seal on the inlet of the cartridge is faulty or seat assembly is damaged.	Check the O-ring & seat for cuts or overheating damage during installation. Replace if necessary.
Water insufficiently hot.	Adjustable handle position stop incorrectly set.	Refer to the instruction on "Setting Temperature Limit Stop".
Valve body too deep into wall.	The measured rough in or finished wall surface is incorrect.	Reset the valve.
Diverter will not stay on during shower.	Not enough backpressure between showerhead and diverter valve.	Flow restrictor @ shower head 2.5 GPM
No or low flow of hot or cold water.	Either the hot or cold side is not fully pressurized.	Verify that all service stops for both the hot and cold are fully open and pressurized.
	Debris caught inside the inlet of the cartridge.	Remove the cartridge (See Page 3). If debris is lodged in the inlet of the cartridge or check the valve located in the cast valve body. The debris can be removed with a straightened paper clip or fine wire. Gently insert the wire and move it in a circular motion to dislodge any debris.

## Care and Cleaning

The lustrous finish on your Restoration Hardware Bathware fixture should be treated with care. Improper handling or cleaning can damage the surface of any metal finish. Use a soft cloth to wipe clean. Avoid harsh abrasive cleaner. Water contains lime and other mineral deposits that will be left on the surface after the water has evaporated. You can prevent these deposits from forming by always wiping the fixture dry immediately after use.

## Technical Support and Customer Service

For technical support in the installation of your Restoration Hardware Bathware fixture, please call 1-866-417-5207 weekdays between the hours of 7:00am and 4:00pm PST.

For other questions regarding your order, to order additional components of the Restoration Hardware Bathware Collection, to order replacement parts, or to address warranty issues, please contact Restoration Hardware Customer Service at 1-877-747-4671.