

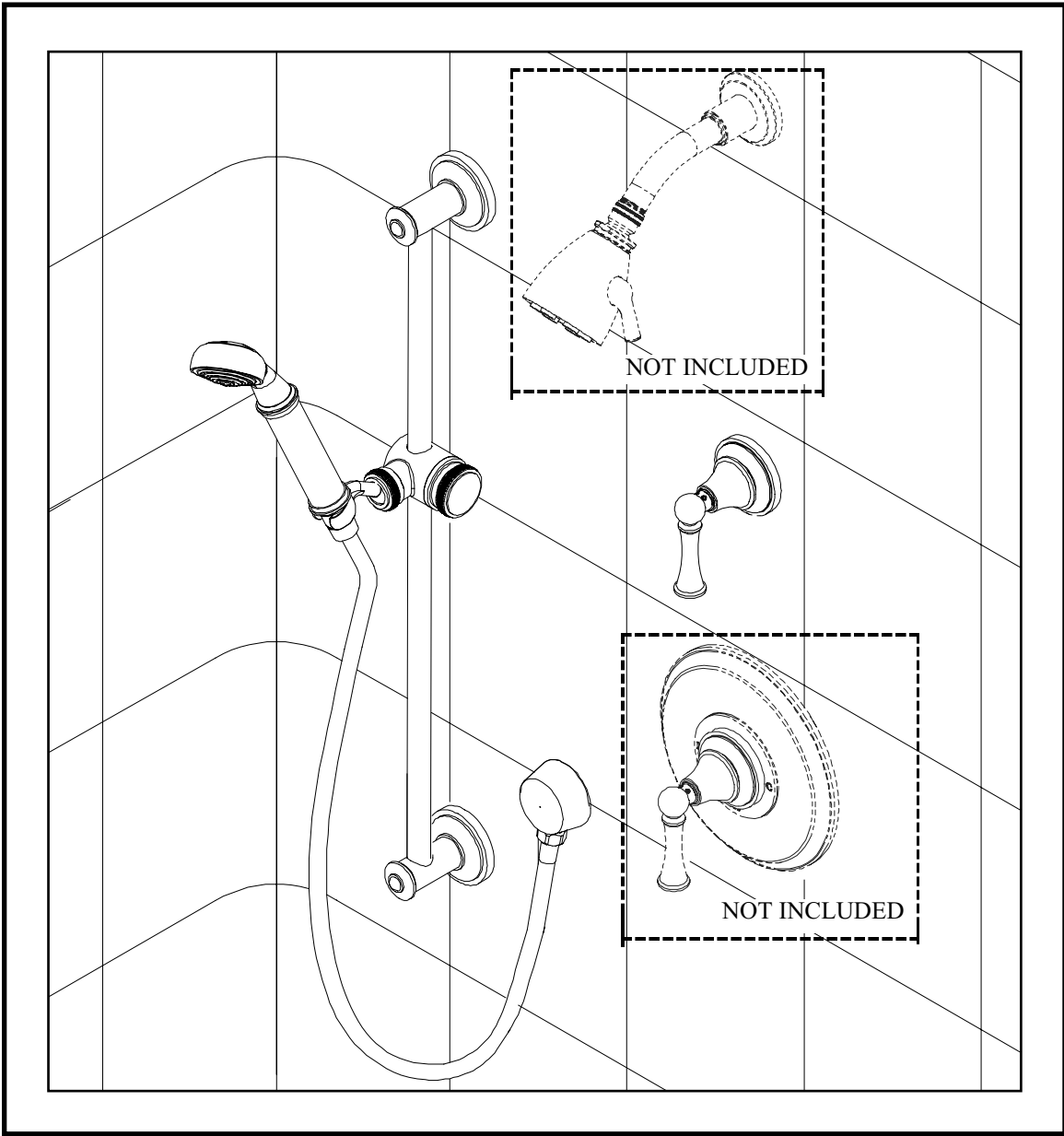

INSTALLATION INSTRUCTIONS



MODEL: CHATHAM
HAND SHOWER SET
(RH-5543)

Restoration Hardware Hand Shower / Slide Bar Specification Diagram

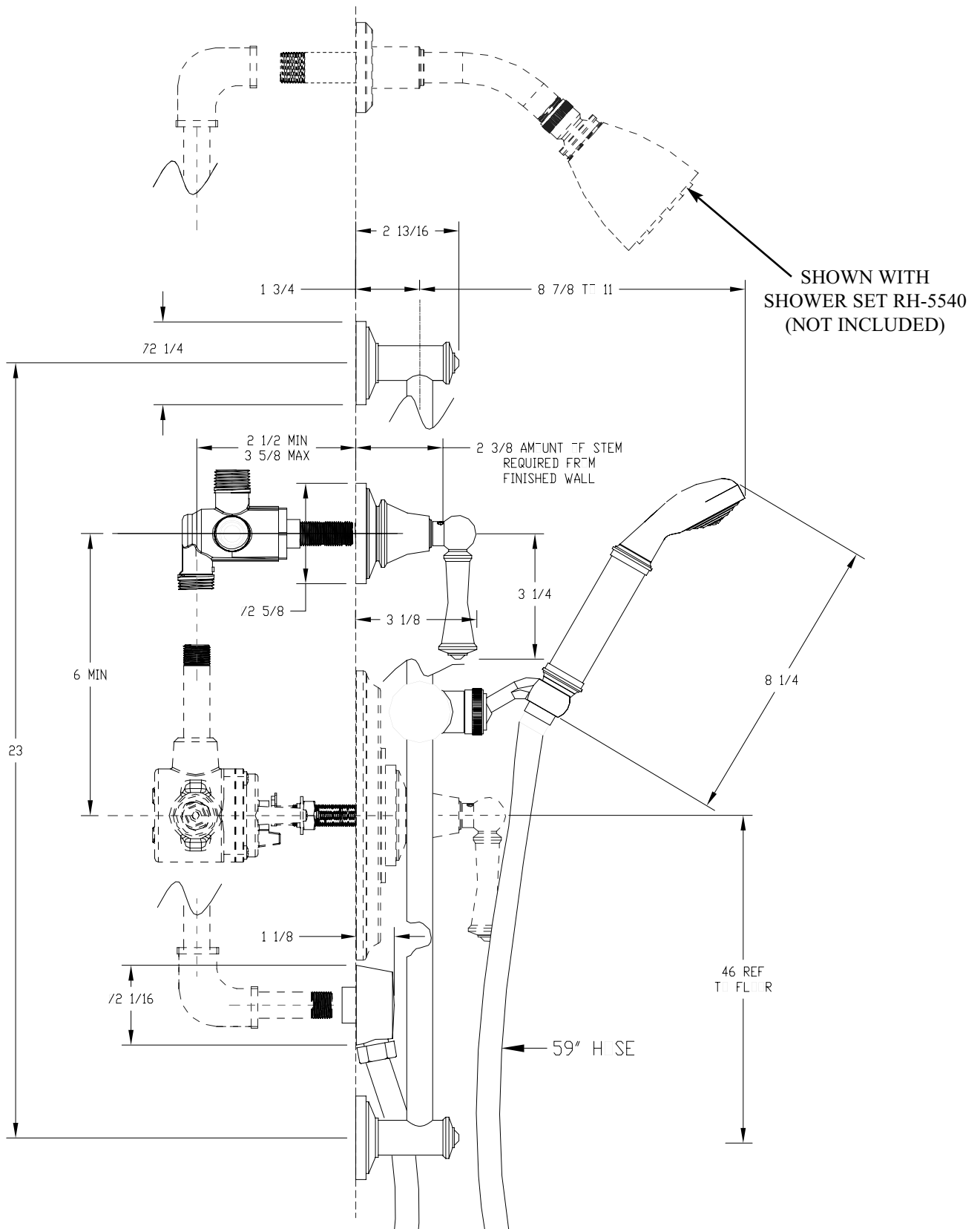

All Threaded Connections are 1/2" NPT
Dimensions are in Inches and Approximation of a Typical Installation

Common tools needed:

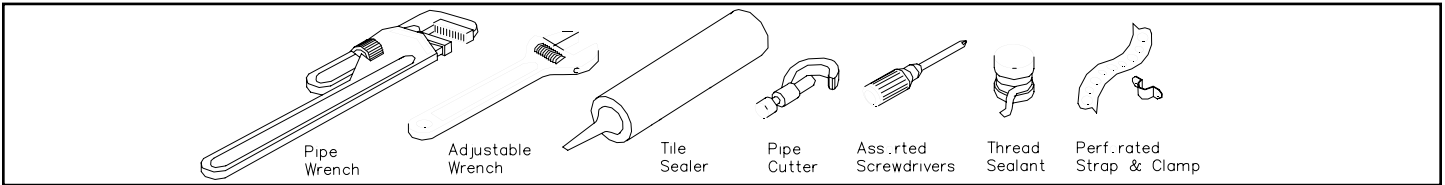

Installation Instructions

We recommended Installation by a Licensed Plumbing Professional

1. Valve Prep and Installation

- Diverter valve supplied in 3-way mode, (designed for 3 end devices). 2-way WASHER (1) supplied separately and must be used in place of the 3-way WASHER (2) for this application. Additional output device can be added, in this case, the 3-way WASHER (2) is required.
- To change valve to 2-way mode, remove NIPPLE (3), STEM (4) and Diverter NUT (5). See **Figure 1**.

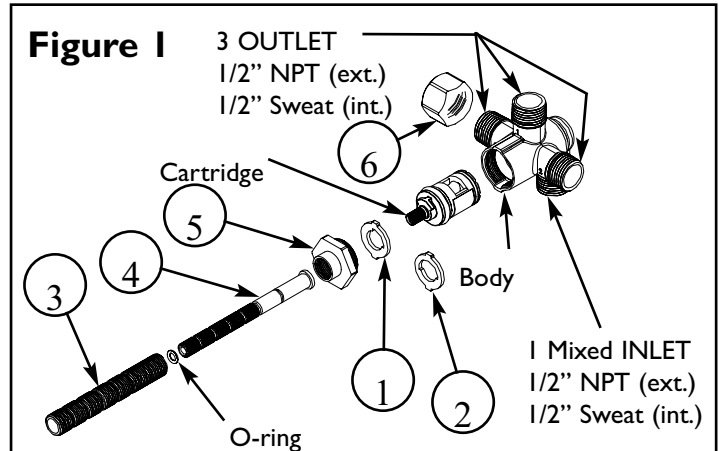

Replace the 3-way WASHER (2) with the 2-way WASHER (1) and orientation for your application, per **Diagram 1a** or **1b**. **Note:** The unused “OUT” port CAN NOT be used as shut off.

- Re-assemble Diverter NUT (5), STEM (4) and NIPPLE (3).
- Apply thread sealant to the 1/2 NPT CAP (6) and thread onto the unused “OUT” port 2 or 3.
- Diverter valve is used with a mixed (hot & cold) input, (i.e. Balance Pressure or Thermo Valve). Position valve with the port marked “IN” in the down position. (Connect mixed supply to “IN” port only.) See **Figure 2**.
- Apply thread sealant to supply from shower mixing VALVE (3). Firmly tighten into diverter valve lower port marked “IN”. No soldering should be performed within 4” minimum of valve ports. Whenever possible it is best to perform all soldering/brazing operations on piping prior to attachment to valve.
- Apply thread sealant to SHOWER RISER (4) and attach to valve port marked “1”.
- Apply thread sealant to HAND SHOWER SUPPLY (5) and attach to valve open port, “2” or “3”.

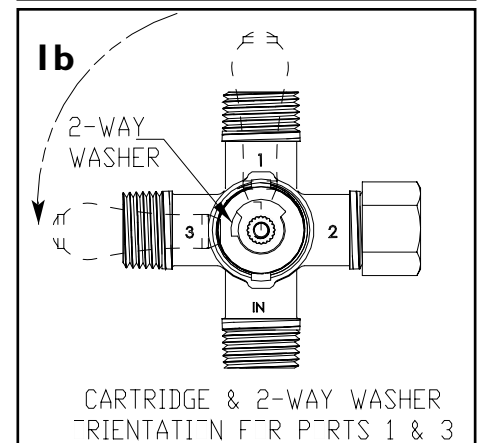
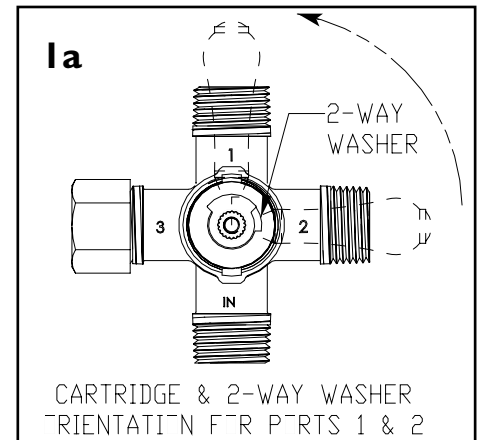

- VALVE (1) and SUPPLY/OUTPUT (4, & 5) must be secured to a CROSS BRACE (6) using PERFORATED STRAP (7) or equivalent.
- Position VALVE (1) from finished wall as mentioned on specification diagram.
- Attach various plumbing fittings in appropriate locations to SHOWERHEAD SUPPLY (4) and HAND SHOWER SUPPLY (5).
- Secure temporary PLUGS (8), (not supplied), into output fittings.
- Turn on both water supplies to valve and check for leaks. **Note:** Water pressure must be applied to both hot and cold inlet ports of mixing VALVE (1) for proper operation.
- Rotate VALVE (1) stem to both rotational extremes to check for leaks at VALVE (1) and SUPPLY OUTPUT (4, & 5).
- After inspection turn off water supply.

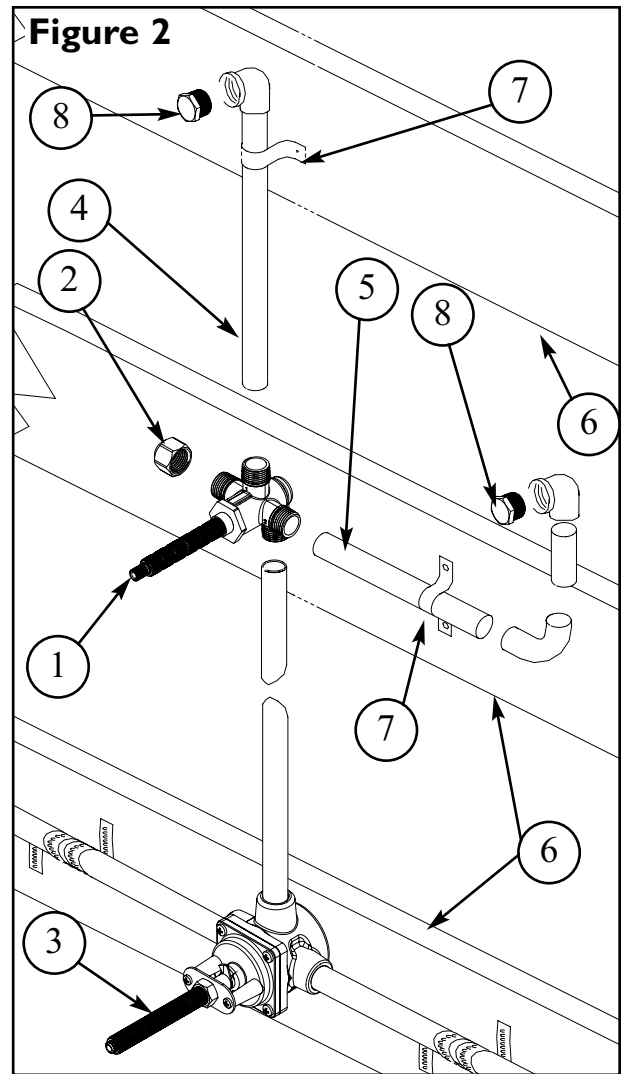

2. Valve Trim Installation

(Perform these steps after finished wall has been completed). See **Figure 3**.

- The STEM (3) must be trim to 2 3/8" from finished wall. Remove STEM (3) by loosening NUT (2) and removing NIPPLE (1), NUT (2), and STEM (3). Trim stem to previously mentioned length.
- The NIPPLE (1) must be trimmed to 1-7/8" from finished wall or 1/2" less than STEM (3).
- Fasten STEM (3) and NIPPLE (1) onto VALVE (4). Use NUT (2) to lock NIPPLE (1) into place. Rotate stem to ensure STEM (3) is not binding. If binding, loosen NIPPLE (1) until STEM (3) moves freely and does not wobble.
- Place ESCUTCHEON (5) and BONNET (6) onto NIPPLE (1) and firmly tighten BONNET (6) in place to secure trim onto VALVE (4).
- Secure HANDLE (7) into place with SET SCREWS (8) provided.

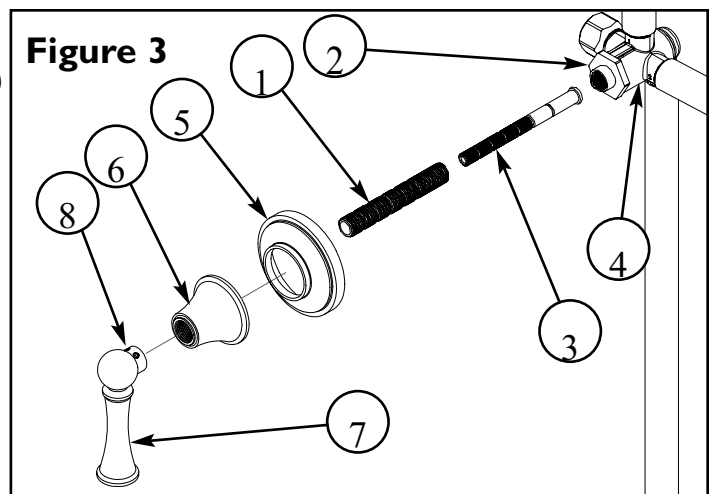

3. Installation of Slide Bar Assembly

- Locate the desired position of slide bar on finished wall. See Fig. 1.
- Mark wall and drill 5/16" hole for WALL ANCHORS (1) to dimension shown in Figure 1.
- Place SLIDE BAR (2) into END POST (3). Note: Large diameter hole in SLIDE BAR (2) must face out as shown in Figure 2.
- Place POST (3) onto ESCUTCHEON (4), insert SCREW (5) & securely tighten into ANCHOR (1) as shown in Figure 2.
- Press END CAP (6) into end of POST (3).
- Slide and lock HOLDER ASSEMBLY (7) onto SLIDE BAR (2) and repeat the above steps to the other end of SLIDE BAR (2) as shown in Figure 3.

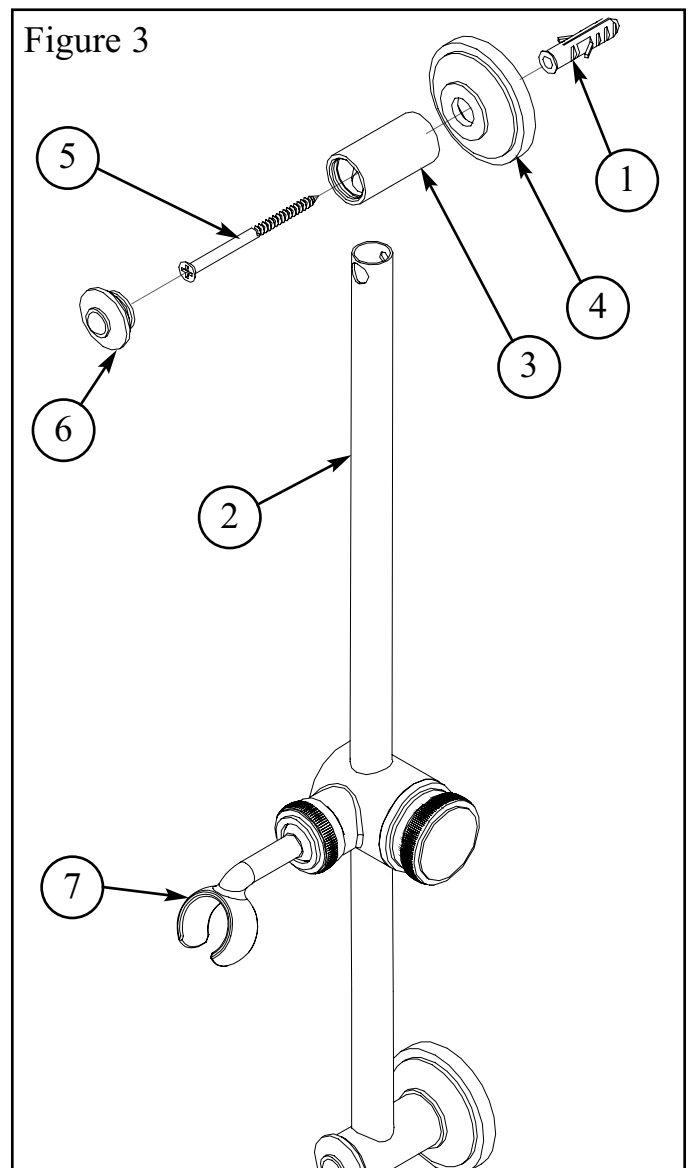
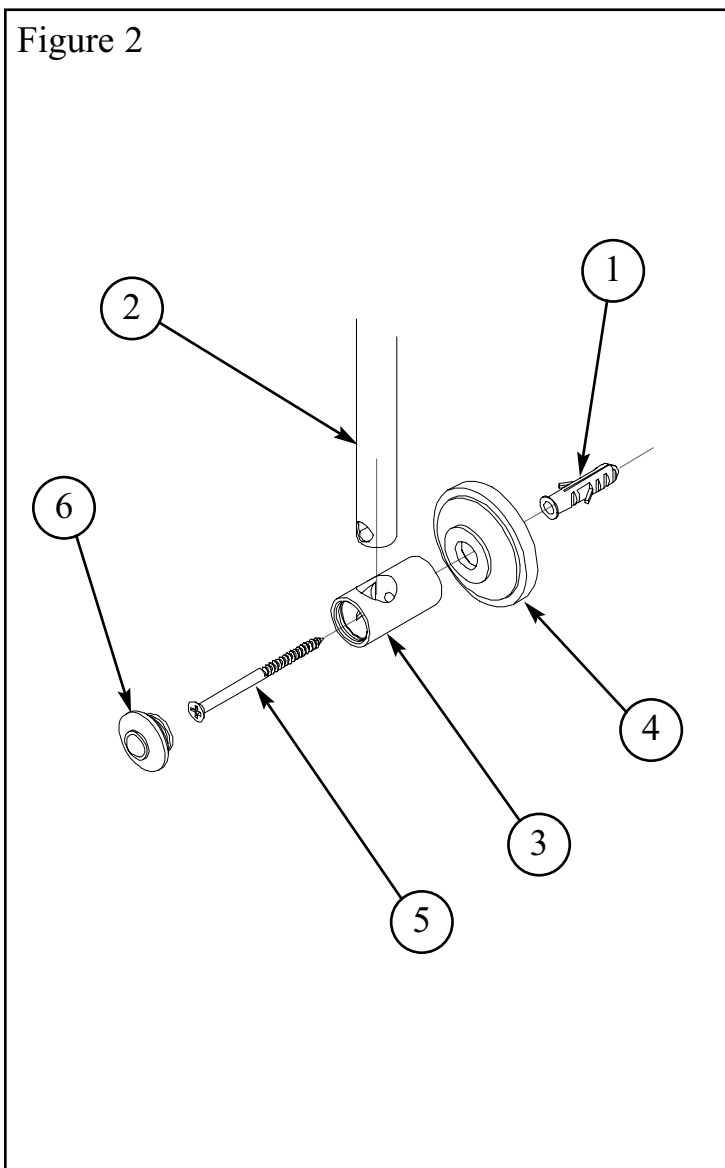
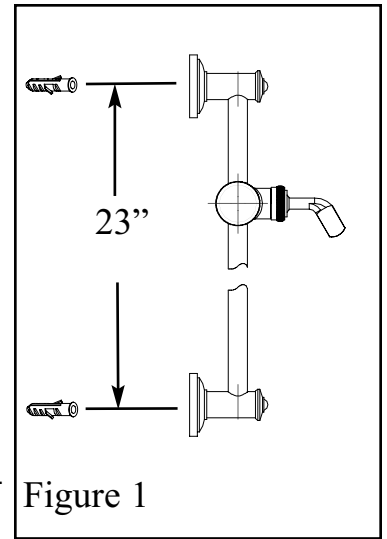

4. Supply Elbow Installation

- Remove TEMPORARY PLUG (1) from fitting in wall.
- Apply thread sealant to both ends of appropriate length NIPPLE (2), (not supplied).
- Tighten NIPPLE (2) onto SUPPLY FITTING (4).
- Tighten SUPPLY ELBOW (3) onto NIPPLE (2).

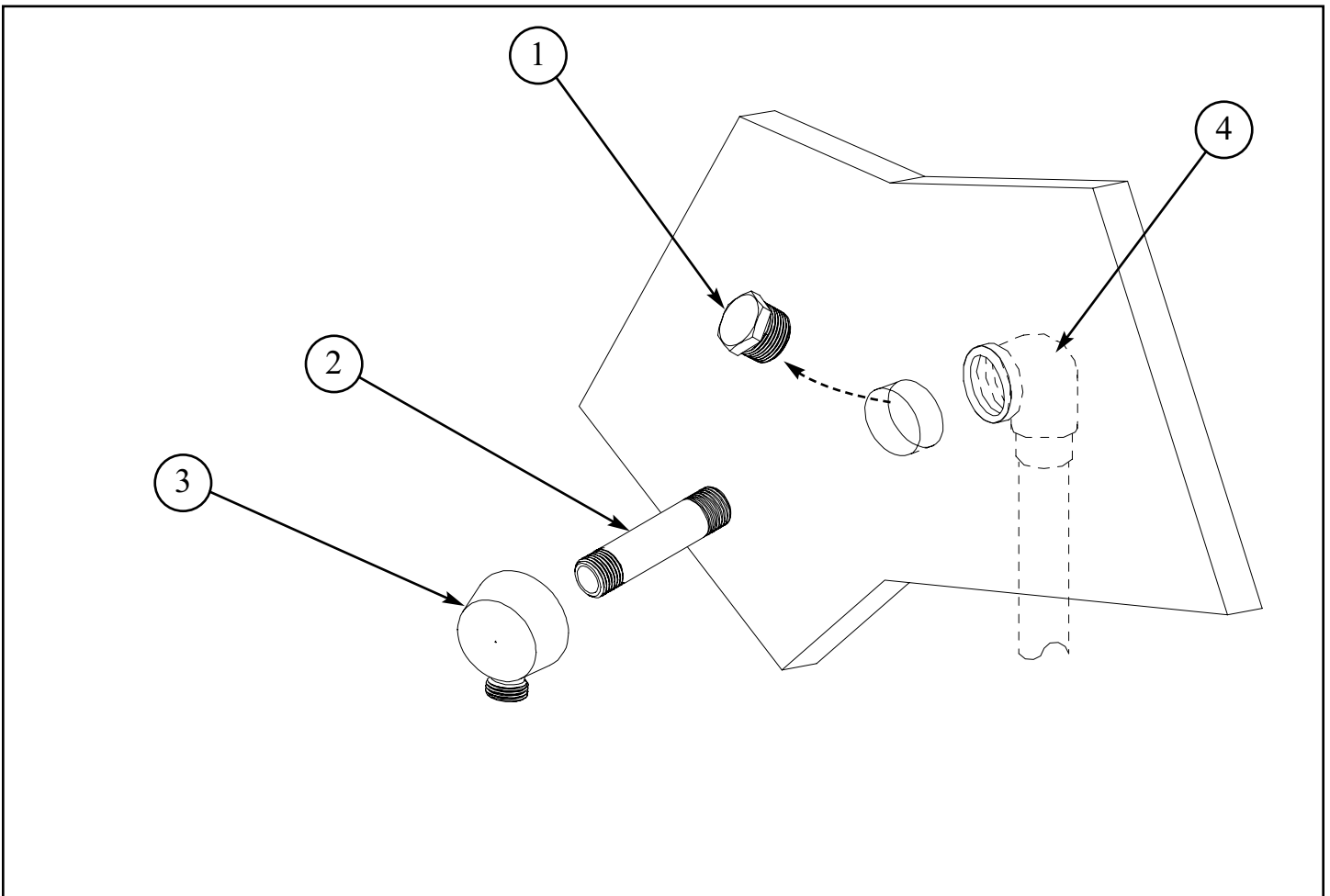

5. Hand Shower & Hose Installation

- Place RUBBER WASHER (1) into both ends of HOSE (2).
- Attach the hex end of HOSE (2) onto SUPPLY ELBOW (3).
- Attach HAND SHOWER (4) onto conical end of HOSE (2).
- Place HAND SHOWER (4) into SLIDE BAR HOLDER (5).

6. Adjusting Hand Shower on Slide Bar

- Loosen or tighten COLLAR NUT (6) to allow HOLDER (5) movement to desired position.
- Loosen CAP HANDLE (7) and move HOLDER (5) to desired vertical location. Retighten CAP HANDLE (7) to keep HOLDER (5) in place.

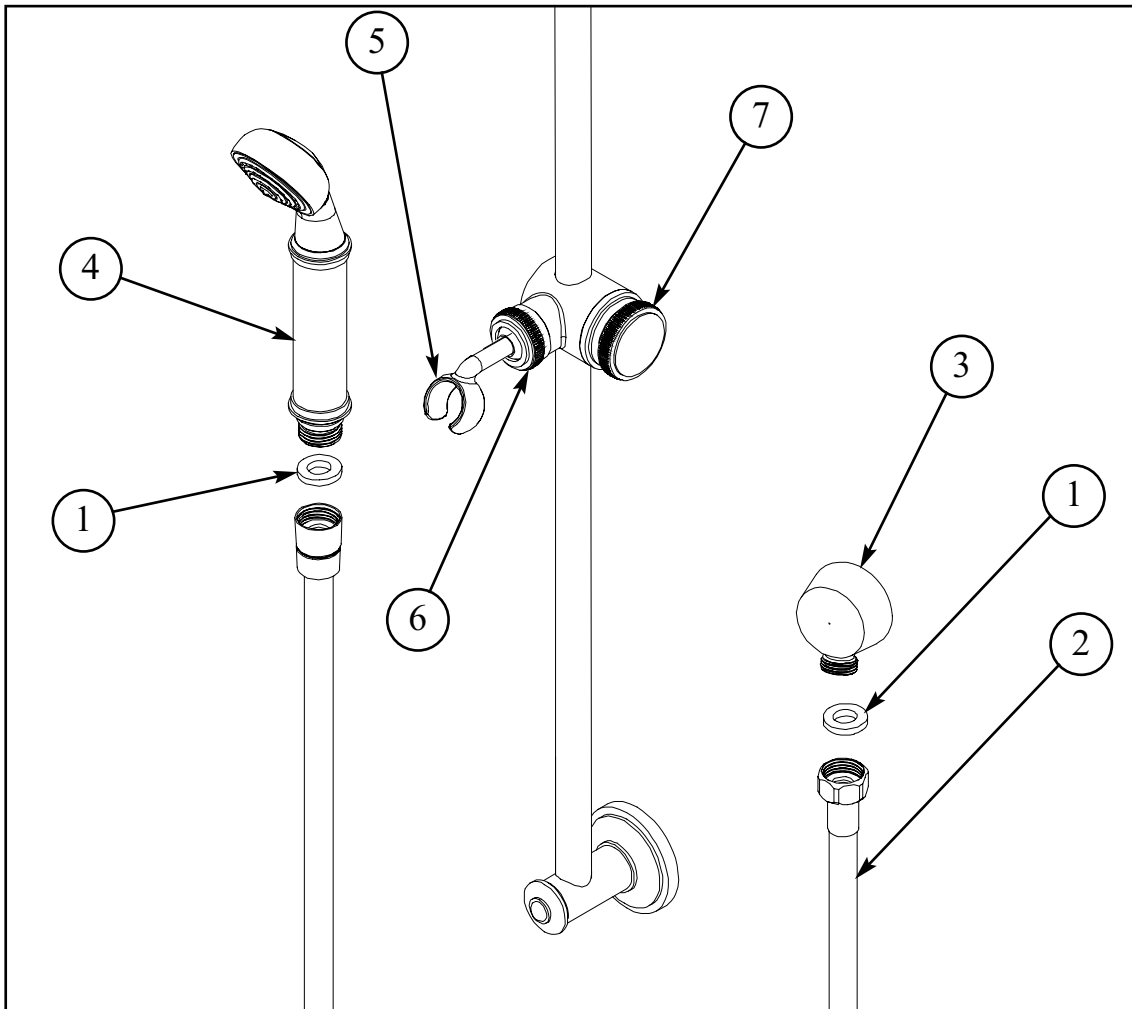

Care and Cleaning

The lustrous finish on your Restoration Hardware Bathware fixture should be treated with care. Improper handling or cleaning can damage the surface of any metal finish. Use a soft cloth to wipe clean. Avoid harsh abrasive cleaner. Water contains lime and other mineral deposits that will be left on the surface after the water has evaporated. You can prevent these deposits from forming by always wiping the fixture dry immediately after use.

Technical Support and Customer Service

For technical support in the installation of your Restoration Hardware Bathware fixture, please call 1-866-417-5207 weekdays between the hours of 7:00am and 4:00pm PST.

For other questions regarding your order, to order additional components of the Restoration Hardware Bathware Collection, to order replacement parts, or to address warranty issues, please contact Restoration Hardware Customer Service at 1-877-747-4671.