

RESTORATION HARDWARE

Thank you for purchasing Restoration Hardware Lighting. Our assortment is crafted with the highest quality details in mind and each collection is clad in one of our signature finish options. Each item's surface is sealed which eliminates the need for polishing and ensures the lasting brilliance of your piece for years to come.

PARTS ENCLOSED:

- | | |
|-----------------------|----------------------------|
| (A) Ceiling Mount (1) | (a) Mounting Screw (2) |
| (B) Plate Screw (2) | (b) Wire Connector (3) |
| (C) Ball Screw (2) | (c) Mounting Plate (1) |
| (D) Mount Lantern (1) | (d) Dimple (2) |
| (E) Screw Caps (2) | (e) Green Ground Screw (1) |
| | (f) Outlet Box Screw (2) |
| | (g) Hexnut (2) |
| | (h) Ground Wire (1) |

IMPORTANT SAFETY INSTRUCTIONS :

WE RECOMMEND INSTALLATION BY A LICENSED ELECTRICIAN.
This fixture has been rated for up to (2) 60-watt maximum TYPE B bulbs.
To avoid the risk of fire, do not exceed the recommended wattage.

WARNINGS :

All wires are connected. When unpacking, be careful not to pull wires as a bad connection may result. Do not connect electricity until your lamp is fully assembled.

To reduce the risk of fire, electrical shock, or personal injury, always turn off and unplug lamp and allow it to cool prior to replacing light bulb.

Do not touch bulb when fixture is turned on or look directly at lit bulb.

Keep flammable materials away from lit bulb.

TO ASSEMBLE:

1. Carefully remove all parts from the box and remove all plastic covering.
2. Turn OFF power to the junction box where the lamp will be installed.
3. Attach the ground wire (h) from the fixture to the ground junction box wire from the outlet box (usually green or bare wire) with a plastic wire connector (b) and wrap the connection with electrical tape. Screw the green ground screw (e) onto the mounting plate (c) near dimples (d), and wrap the fixture's bare ground wire around the ground screw. Then, tighten the screw.
4. Connect the hot wire to the hot junction box wire (usually black) with a plastic wire connector (b) and wrap the connection with electrical tape. Connect the neutral wire to the neutral junction box wire (usually white) with a plastic wire connector (b) and wrap the connection with electrical tape.
5. Attach the mounting screws (a) onto the mounting plate (c), and fix them with hex nuts (g).
6. Attach the mounting plate (c) to the outlet box using the outlet box screws (f). Tighten with a screwdriver.
7. Attach the ceiling plate (A) onto the mounting plate (c) using the enclosed ball screws (C).
8. Insert 2* 60 watt Type B bulbs (not included) into threaded socket.
9. Attach the mount lantern (D) to the ceiling plate (A) using the plate screws (B). Tighten screws with a screw caps (E).
10. Restore power to the junction box and test lamp fixture.
11. Assembly is complete.

CARE INSTRUCTIONS :

Do not use polishes or cleaners on your lamp.
JUST WIPE CLEAN WITH SOFT CLOTH.

MADERA OUTDOOR FLUSHMOUNT

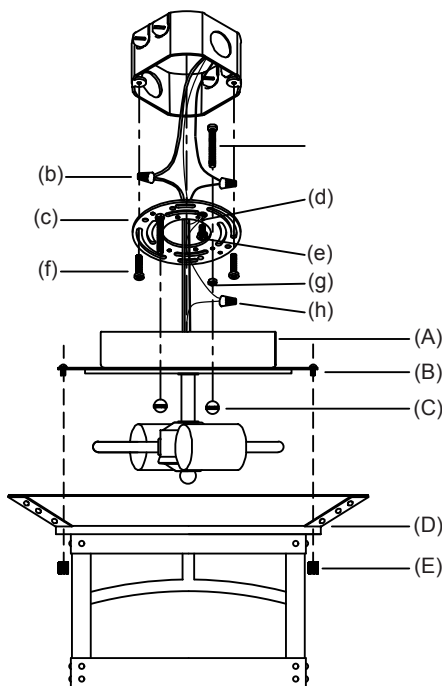

Direct Wire Installation