

## ST. JAMES MARBLE ROUND ENTRY TABLE INSTRUCTIONS

Thank you for choosing this quality product. Be sure to check all packaging materials carefully for small parts that may have become loose during shipment and place all parts on a non-abrasive surface.

### IMPORTANT

These table parts can be cumbersome and heavy; the assistance of two or more people is recommended in order to prevent personal injury and ensure the table parts are not damaged during the assembly process.

### PARTS INCLUDED

- A [1] MARBLE TOP
- B [1] TABLE BASE

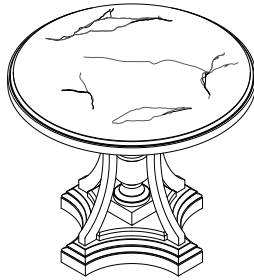

### ASSEMBLY INSTRUCTIONS

1. Place the table base at your desired location.  
Note: On mounting plate of the table base are holes for the bolt to pass through with locator dowel holes that correspond to the holes underneath the tabletop with pre-installed nuts and holes for the locator dowels.
2. Align and insert the wooden dowel (1) into the holes on the top of the table base. Gently lift up the marble top (A) and install on top of the base. Engage Allen head bolt (2) together with plain washers (4) and lock washers (3) (Note: All this hardware is packed together with marble top). Fasten the bolt with Allen wrench (5). Please see FIGURES 1 & 2.
3. Check the table leveling, and adjust the levelers at the bottom of the base if necessary. See FIGURE 3. Assembly is complete.

### HARDWARE INCLUDED





NO.	ITEM	DESCRIPTION	QTY.
1		Wooden dowel	2 pcs.
2		Allen bolt	4 pcs.
3		Lock washer	4 pcs.
4		Plain washer	4 pcs.
5		Allen wrench	1 pc.

FIGURE 1

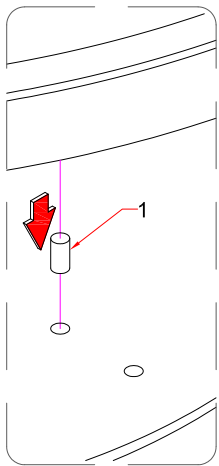
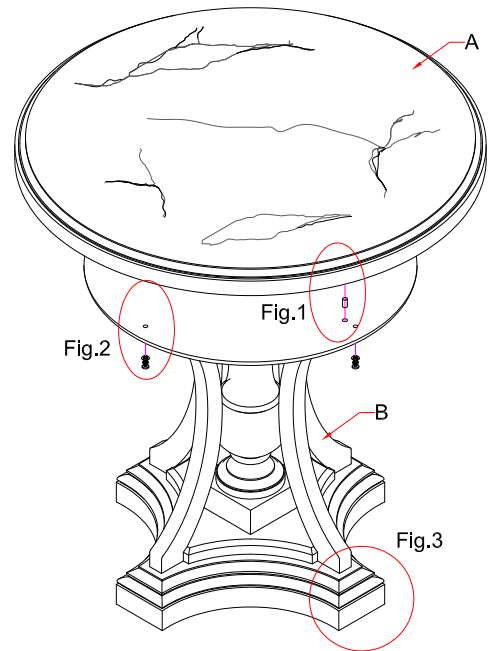
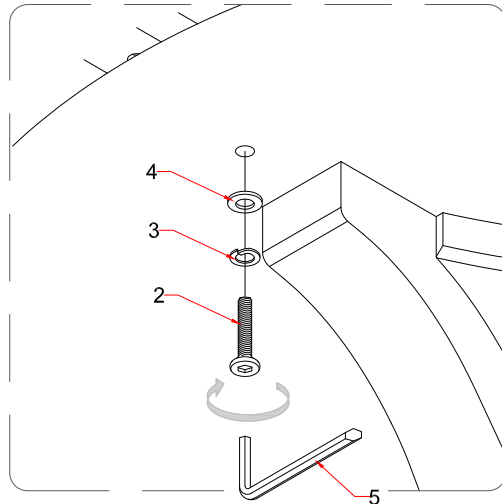

FIGURE 2



### CARE INSTRUCTIONS

1. Dust often using a clean, soft, dry and lint-free cloth.
2. Blot spills immediately and wipe with a clean, damp cloth.
3. We do not recommend the use of chemical cleansers, abrasives or furniture polish on our lacquered finish.

### IMPORTANT SAFETY INSTRUCTIONS

1. Please read all instructions carefully before assembling.
2. For your safety, assembly by two or more adults is strongly recommended.
3. Use only vendor-supplied hardware to assemble. Using unauthorized hardware could jeopardize the structural integrity of the item.

FIGURE 3

