

RESTORATION HARDWARE

PERALTA SCONCE

PARTS ENCLOSED: HARDWARE INCLUDED:

- | | |
|------------------------|--------------------------------|
| (A) Mounting plate (1) | (a) Green ground screw (1) |
| (B) Back plate (1) | (b) Plastic wire connector (3) |
| | (c) Anchor (2) |
| | (d) Anchor screw (2) |
| | (e) Plate screw (6) |
| | (f) Mounting screw (2) |

IMPORTANT SAFETY INSTRUCTIONS:

MAKE SURE THESE ARE INSTALLED BY A PROFESSIONAL OR LICENSED ELECTRICIAN.

WARNINGS:

All wires are connected. When unpacking, be careful not to pull wires as a bad connection may result. Do not connect electricity until your lamp is fully assembled.

Do not touch the LED strip or look directly at lit LED strip.

Keep flammable materials away from lit LED strip.

LED module is not replaceable, do not break or pull out Led strip.

This lighting fixture contains lead, a chemical know to the State of California to cause cancer, birth defects and other reproductive harm. Wash hands after installing, handling, cleaning or otherwise touching this light fixture.

TO ASSEMBLE:

1. Carefully remove all parts from the box and remove all plastic covering.
2. Turn OFF power to the junction box where the lamp will be installed.
3. Attached the ground wire from the fixture to the ground junction box wire from the outlet box (usually green or bare wire) and wrap the connection with electrical tape. Screw the green ground screw (a) into the mounting plate (A), and wrap the bare ground wire around the ground screw.
4. Refer to the wiring diagram provided for accurate wire connections.
5. Mark the location of the mounting holes on the wall using a pencil. using the marks as a guide, drill holes for the wall anchor (c). insert the wall anchors into the holes, using a hammer to fully insert until flush with the wall.
6. Attach the mounting plate (A) to the junction box using the anchor screws (d). Tighten with a screwdriver.
7. Fasten the mounting screws (f) into junction box with screwdriver.
8. Attach the back plate (B) to the mounting plate (A) using plate screw (e) and tighten with a screwdriver.
9. Restore power to the junction box and test lamp fixture.
10. Installation is completed.

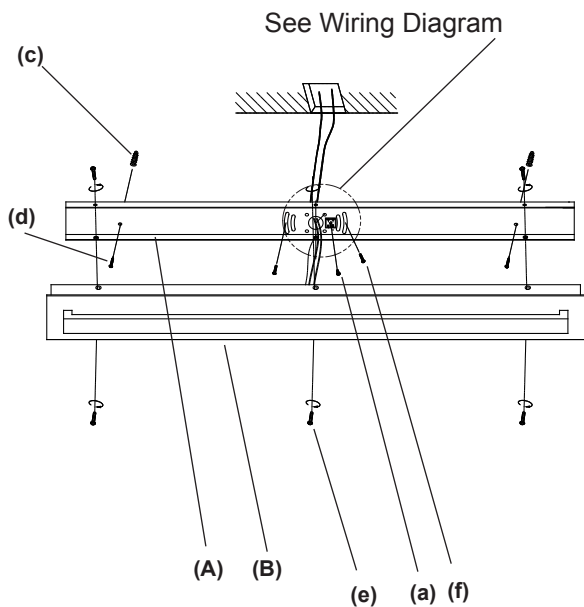

CARE INSTRUCTIONS:

Do not use polishes or cleaners on your lamp.
JUST WIPE CLEAN WITH SOFT CLOTH.

Wiring Diagram

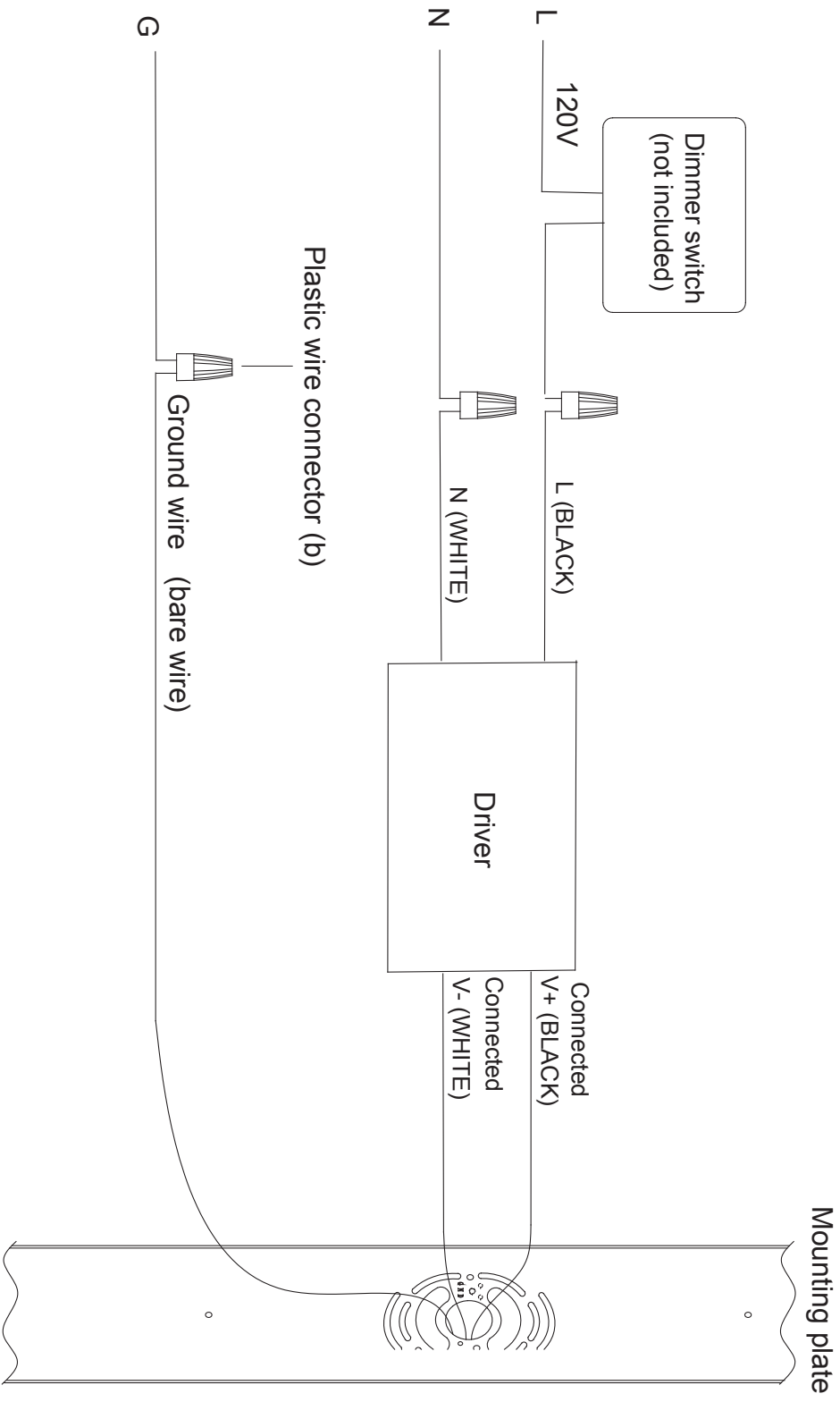

Note :

1. THIS DRIVER IS DESIGN TO BE INSTALLED WITH COMPATIBLE FORWARD PHASE AND TRIAC DIMMERS. ONLY USE RECOMMENDED LUTRON DIMMER SWITCH: MACL-153M, DVCL-153P OR CTCL-153P.
2. Connect above wires with the plastic wire connectors (b) and wrap the connection with electrical tape.
3. DO NOT test or install with an ON/OFF switch and/or without an attached load.