

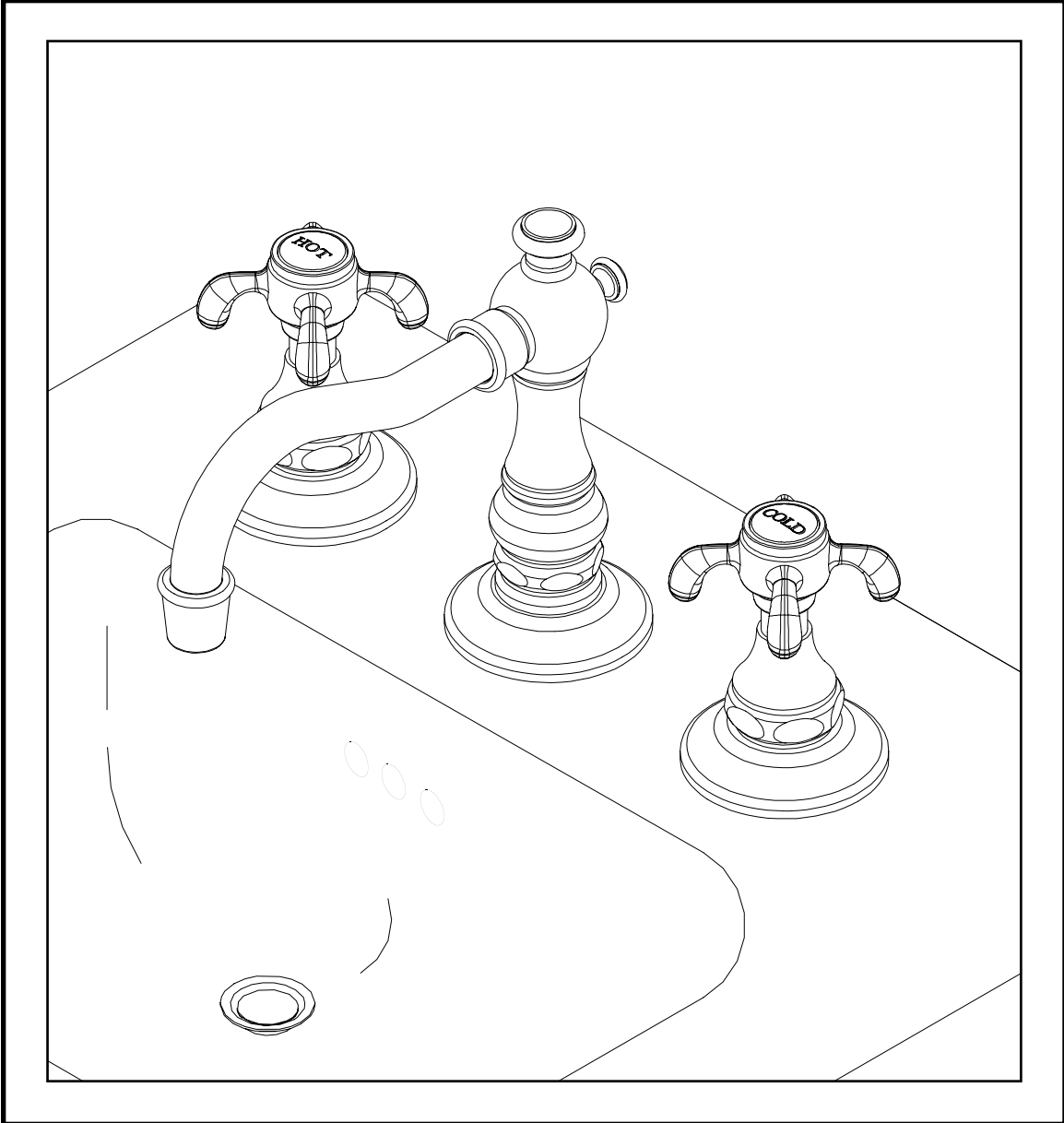

# INSTALLATION INSTRUCTIONS



MODEL: BISTRO  
(RH-5300)

# Restoration Hardware Faucet Product Size Specification Diagram

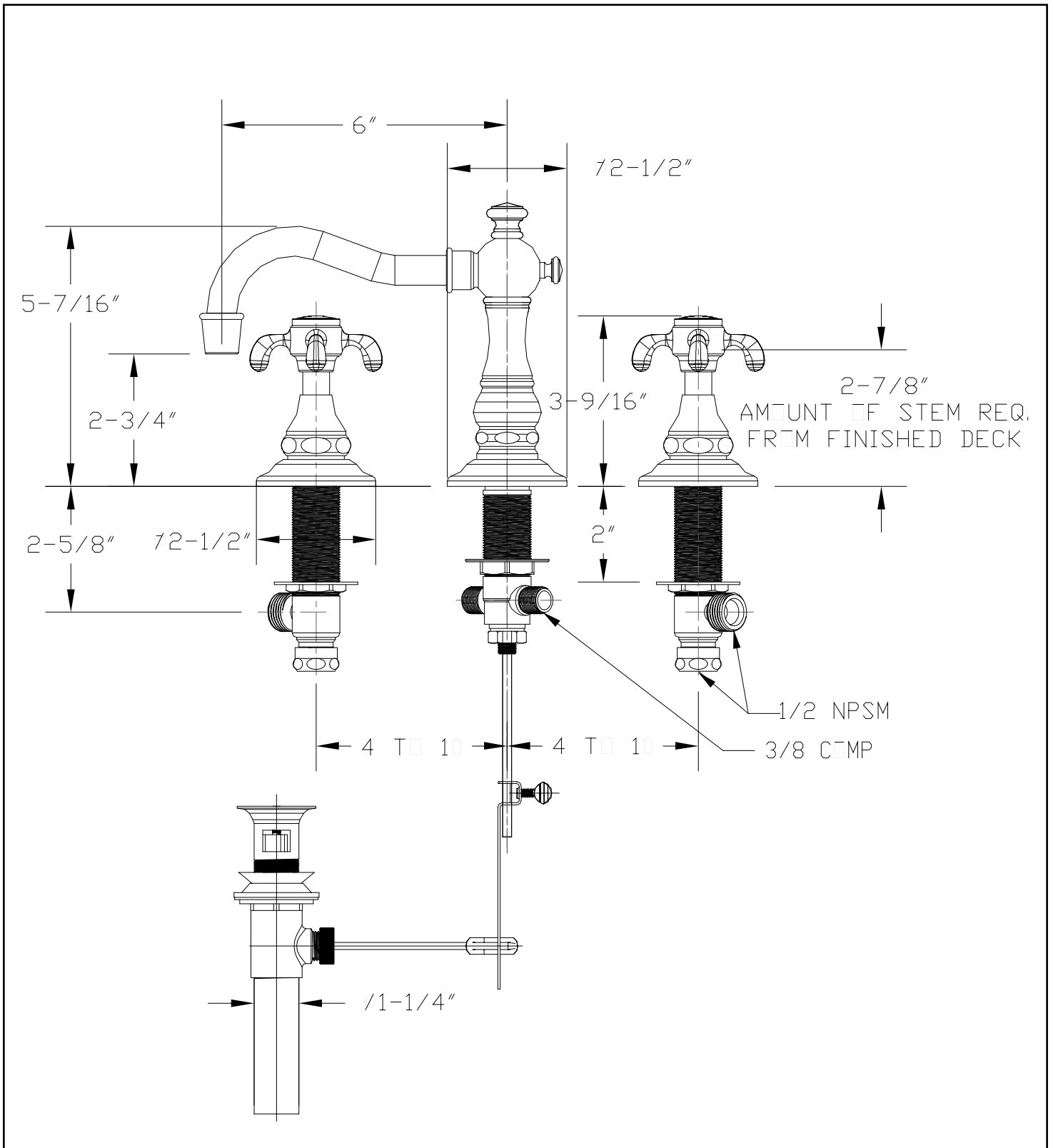

Recommended Deck Hole Size  $1-1/4"$  Diameter  
Dimensions are in Inches and Approximation of a Typical Installation

## Common tools needed:

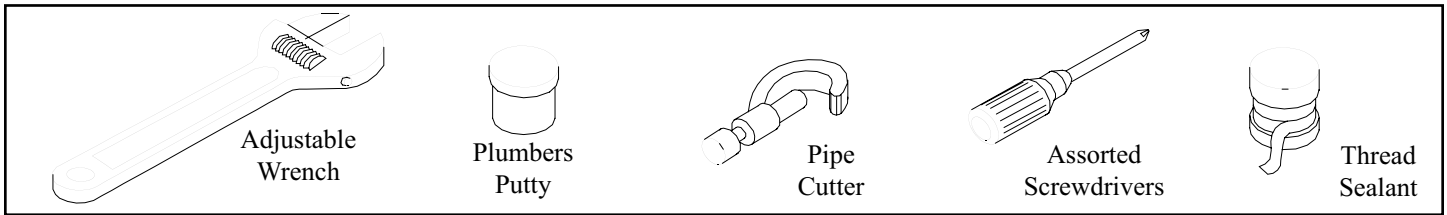

## Installation Instructions

We Recommend Installation by a Licensed Plumbing Professional

### 1. Spout Assembly

- Thread spout SHANK (3) with threaded NIPPLE (2) onto SPOUT (1).
- Insert SHANK (3) and NIPPLE (2) through sink hole, (apply putty or silicone to underside of SPOUT (1)).
- Align SPOUT (1) and secure into place with flange NUT (4).

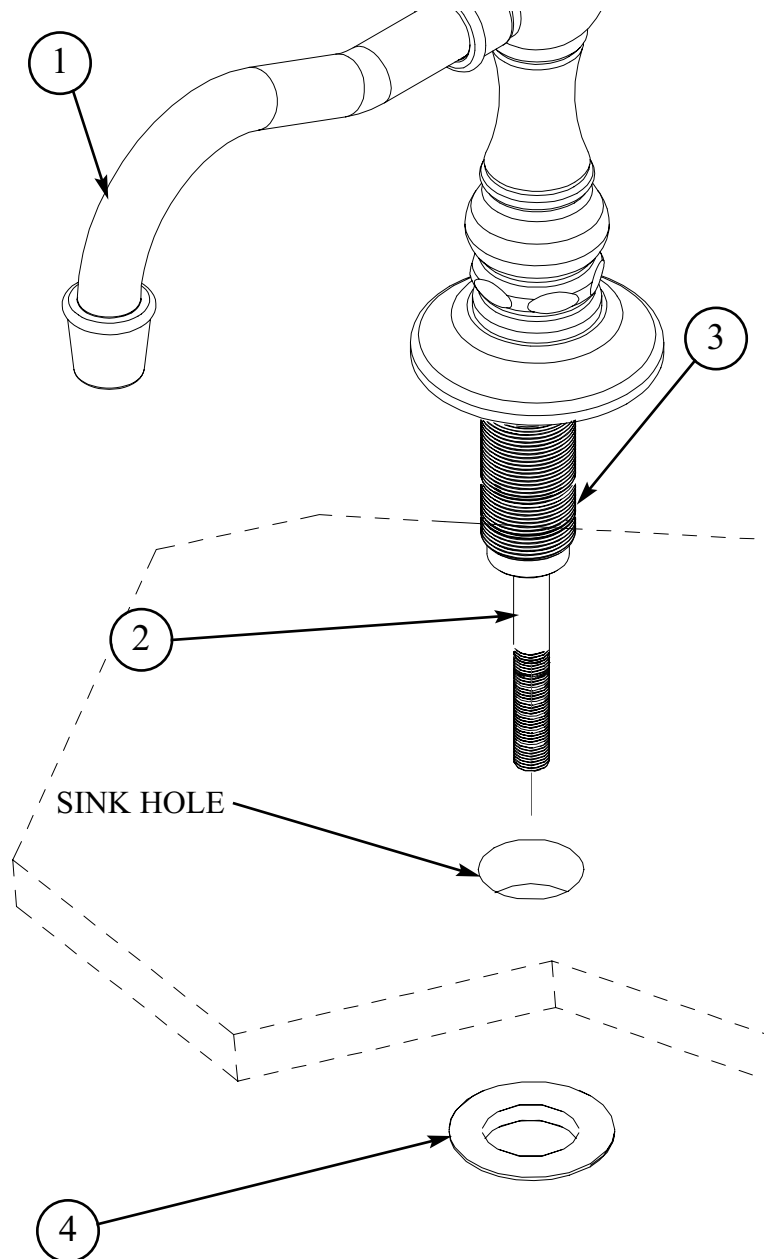

## 2. Valve Assembly

- Place flange NUT (1) and fiber WASHER (2) onto valve BODY (3).
- Insert valve BODY (3) through sink hole from underside of sink. Valve BODY (3) should extend 2-7/8" above mounting surface. If necessary adjust lower flange NUT (1).
- Place fiber WASHER (2) and flange NUT (1) onto upper position of valve BODY (3).
- Set valve BODIES (3,3A) so that their outlets are facing towards the center of the sink and tighten upper flange NUT (1).

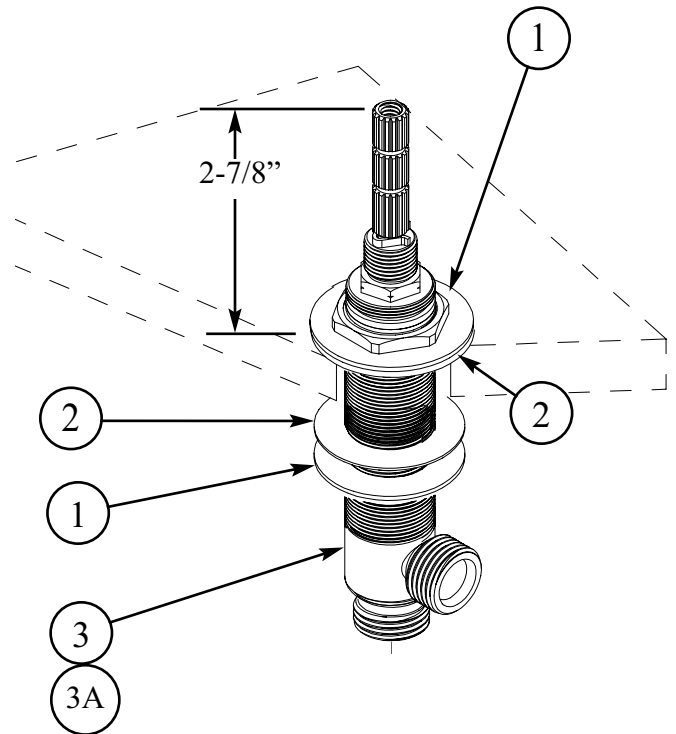

## 3. Tee and Hose Assembly

- Assemble white WASHER (2), brass TEE (3), rubber WASHER (4), brass WASHER (5), and hand tighten lock NUT (6) onto spout SHANK (1).
- Connect larger coupling NUT (8) to outlet of each valve BODY (7, 7A).
- Connect smaller coupling NUT (9) to each inlet of brass TEE (3).
- Hand tighten and secure each coupling NUT (8, 9) with a wrench 1/4 turn.
- Using a wrench **FIRMLY** tighten lock NUT (6) onto spout SHANK (1).

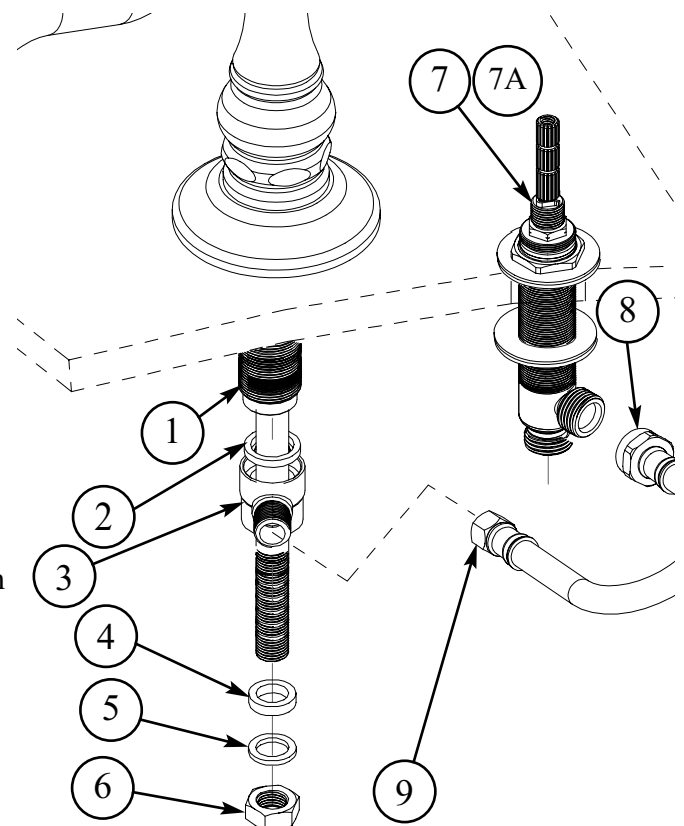

# 4. Make Water Supply Connections

NOTE: SUPPLY RISERS MUST BE PURCHASED SEPARATELY

- Connect water supply to VALVE BODIES(1, 1A) with one of the three following types of risers:
  - a. 1/2" IPS FLEXIBLE RISER (2), discard RUBBER NOSECONE (7), FRICTION WASHER (3) and COUPLING NUT (4).
  - b. 3/8" or 1/2" O.D. BULLNOSE RISER (5), place FRICTION WASHER (3) and COUPLING NUT (4) onto BULLNOSE RISER (5).
  - c. 1/2" O.D. COPPER RISER (6), place COUPLING NUT (4), FRICTION WASHER (3), and RUBBER NOSECONE (7) onto end of COPPER RISER(6).
- Use adjustable wrench to tighten connections. Do not over tighten and be careful not to kink copper supply when bending. Use a tube bender and cutter to properly adjust copper supply.

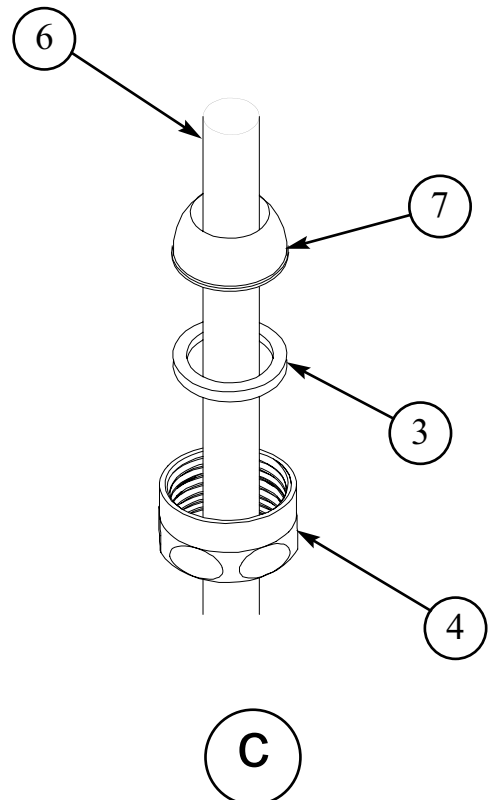
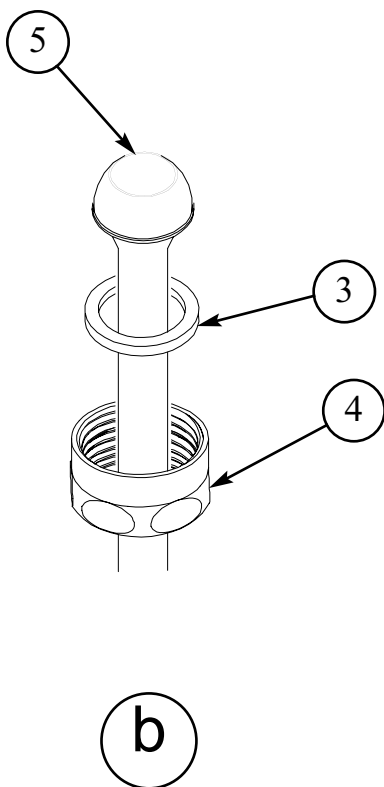
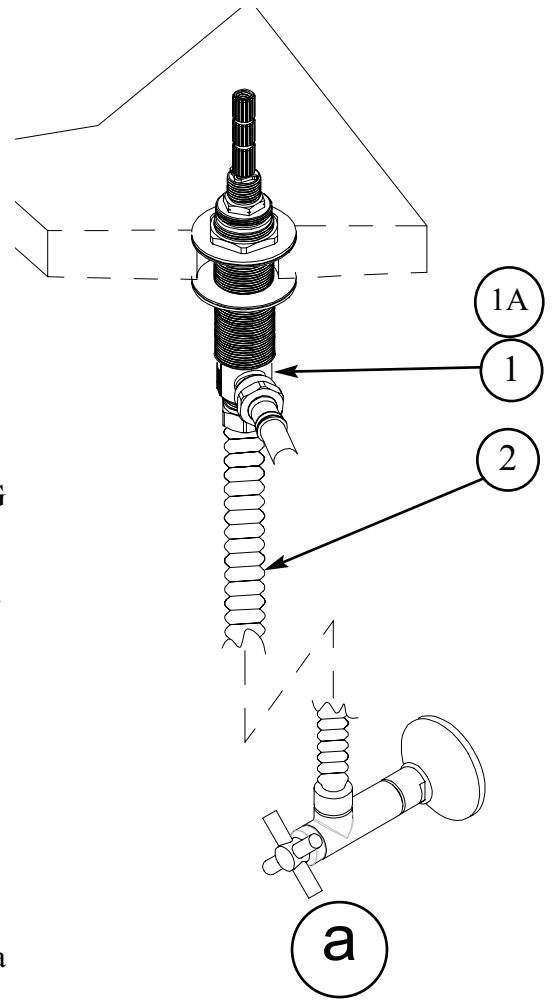

## 5. Install Handles

- Turn valve STEM (7) to OFF position.
- Place ESCUTCHEON (6) onto valve STEM (7) and thread BONNET (5) until snug against ESCUTCHEON (6).
- Place HANDLE (4) onto valve STEM (7). Check alignment, if necessary reposition handle on stem or rotate body for proper alignment. DO NOT loosen cartridge stem.
- Secure HANDLE (4) into place by tightening SCREW (3).
- Remove adhesive backing from desired BUTTON (1) and place onto handle CAP (2).
- Place CAP (2) onto HANDLE (4).

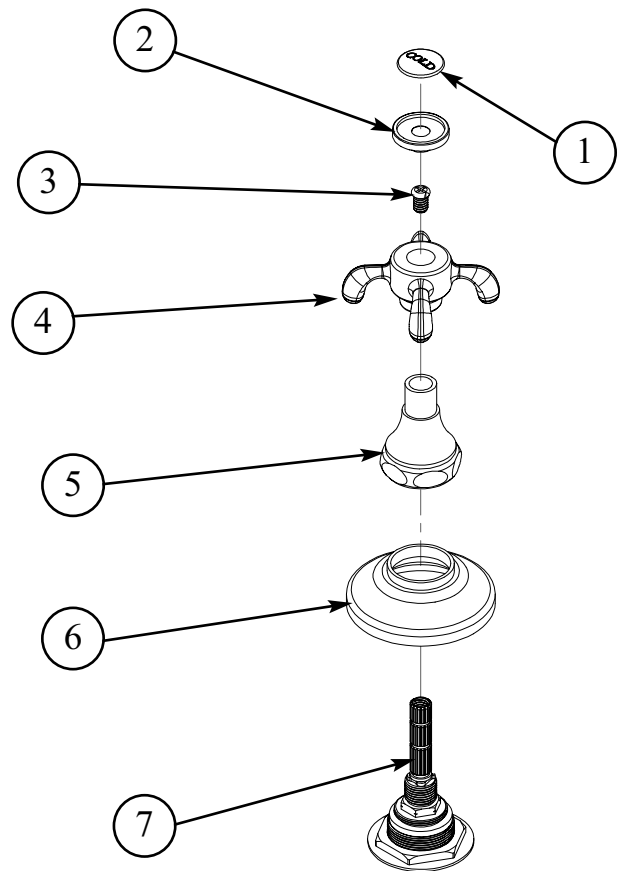

# 6. Install Pop- up Drain

- Attach POP- UP KNOB (1) onto POP- UP ROD (2) and insert through hole on SPOUT (3).
- Place DRAIN FLANGE (5) with WHITE WASHER (6) in place through sink drain hole.  
**Note:** putty or silicone may be used instead of WHITE WASHER (6).
- From underside of sink install RUBBER CONE WASHER (7), FLAT WASHER (8), and FLANGE NUT (9) onto DRAIN FLANGE (5). Tighten FLANGE NUT (9) firmly.
- Place CLEAR WASHER (10) into DRAIN BODY (11) and tighten onto DRAIN FLANGE (5) aligning ball rod port to rear of sink.
- Secure BALL ROD (12) into DRAIN BODY (11) with BALL NUT (13).
- Apply thread sealant onto threads of TAILPIECE (17) and tighten into DRAIN BODY (11).
- Secure TAILPIECE ( 17) to TRAP DRAIN (18) . If necessary trim TAILPIECE (17) for proper fit.
- Position STRAP (15) onto POP- UP ROD (2) and tighten SCREW (16).
- Remove one end of CLIP (14) from BALL ROD (12) by squeezing ends together while sliding.
- Insert BALL ROD (12) into lower holes of STRAP (15) and reassemble CLIP (14).
- Place STOPPER (4) into DRAIN FLANGE (5) and by twisting stopper attach to BALL ROD (12).
- Adjust stopper height by repositioning STRAP (15) on the POP- UP ROD (2) and tightening SCREW (16).

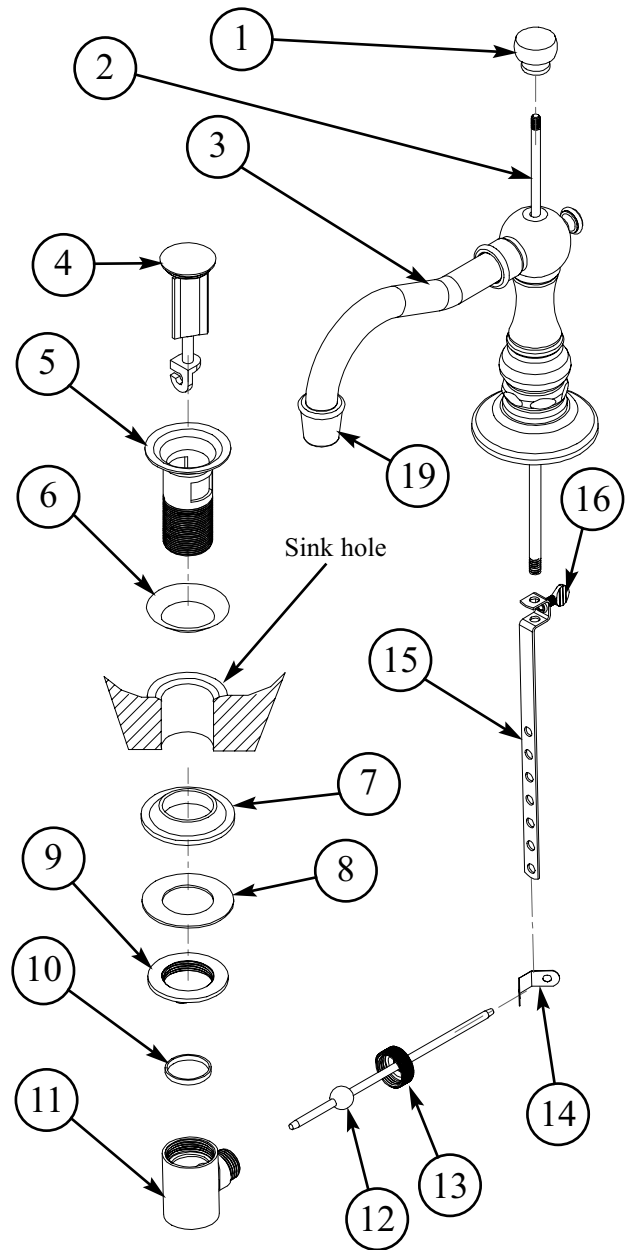

# 7. Test Installed Faucet

- With handles in OFF position, turn on water supplies and check all connections for leaks.
- Remove AERATOR (19) from SPOUT (3).
- Operate both handles to flush water lines thoroughly.
- Reattach AERATOR (19) from SPOUT (3).
- Operate pop-up drain assembly and check for leaks.

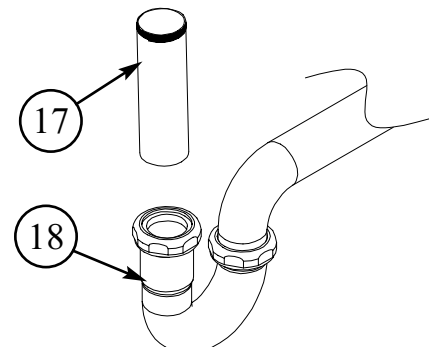

## Care and Cleaning

The lustrous finish on your Restoration Hardware Bathware fixture should be treated with care. Improper handling or cleaning can damage the surface of any metal finish. Use a soft cloth to wipe clean. Avoid harsh abrasive cleaner. Water contains lime and other mineral deposits that will be left on the surface after the water has evaporated. You can prevent these deposits from forming by always wiping the fixture dry immediately after use.

## Technical Support and Customer Service

For technical support in the installation of your Restoration Hardware Bathware fixture, please call 1-866-417-5207 weekdays between the hours of 7:00am and 4:00pm PST.

For other questions regarding your order, to order additional components of the Restoration Hardware Bathware Collection, to order replacement parts, or to address warranty issues, please contact Restoration Hardware Customer Service at 1-877-747-4671.