

BALANCE-PRESSURE

SHOWER SYSTEMS

BALANCE-PRESSURE VALVES FEATURES & BENEFITS

- Solid brass components.
- Balance-Pressure feature ensures a constant temperature despite changes in water pressure.
- Five gallons/minute flow rate, sufficient to operate one water outlet at a time.
- Includes all attendant trim to coordinate with select bath fittings collections.

Other Components (sold separately):

- Multi-Port Diverter Valve & Trim Set
 - Directs water to flow to one of up to three water outlets.
 - Does not support more than one outlet running at a time.

VALVE SPECS

NOTES:

1. Cut stem to dimension "A"
Cut all - thread $1/2"$ shorter than stem

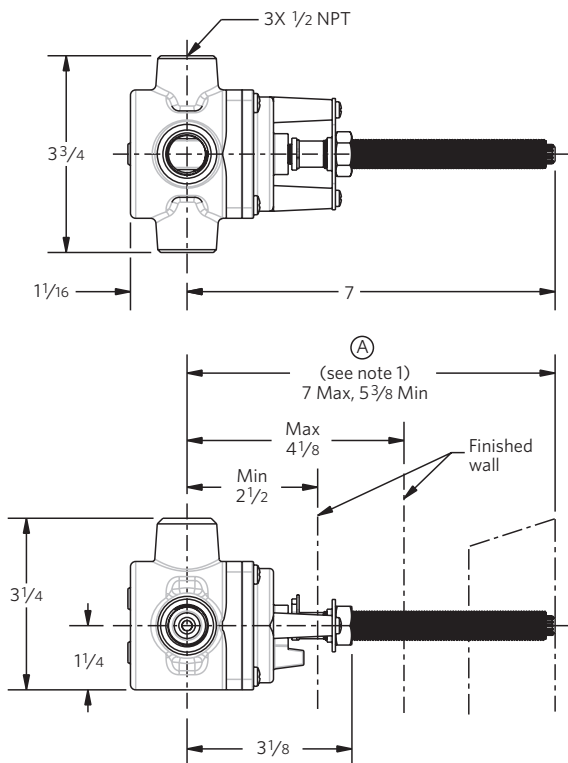

SHOWER ONLY

PARTS REQUIRED

- BP shower valve & trim set
- Shower head, flange & arm



TUB & SHOWER ONLY

PARTS REQUIRED

- BP tub & shower valve & trim set
- Shower head, flange & arm



SHOWER & HANDHELD SHOWER

PARTS REQUIRED

- BP shower valve & trim set
- Shower head, flange & arm
- Handheld shower
- Multi-Port Diverter Valve & Trim set

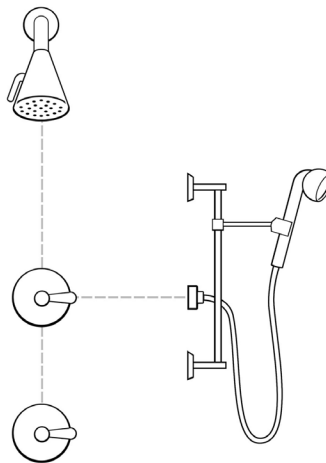

TUB & SHOWER WITH HANDHELD SHOWER

PARTS REQUIRED

- BP tub & shower valve & trim set
- Shower head, flange & arm
- Handheld shower
- Multi-Port Diverter Valve & Trim set

