

RH

RESTORATION HARDWARE

INSTALLATION INSTRUCTIONS

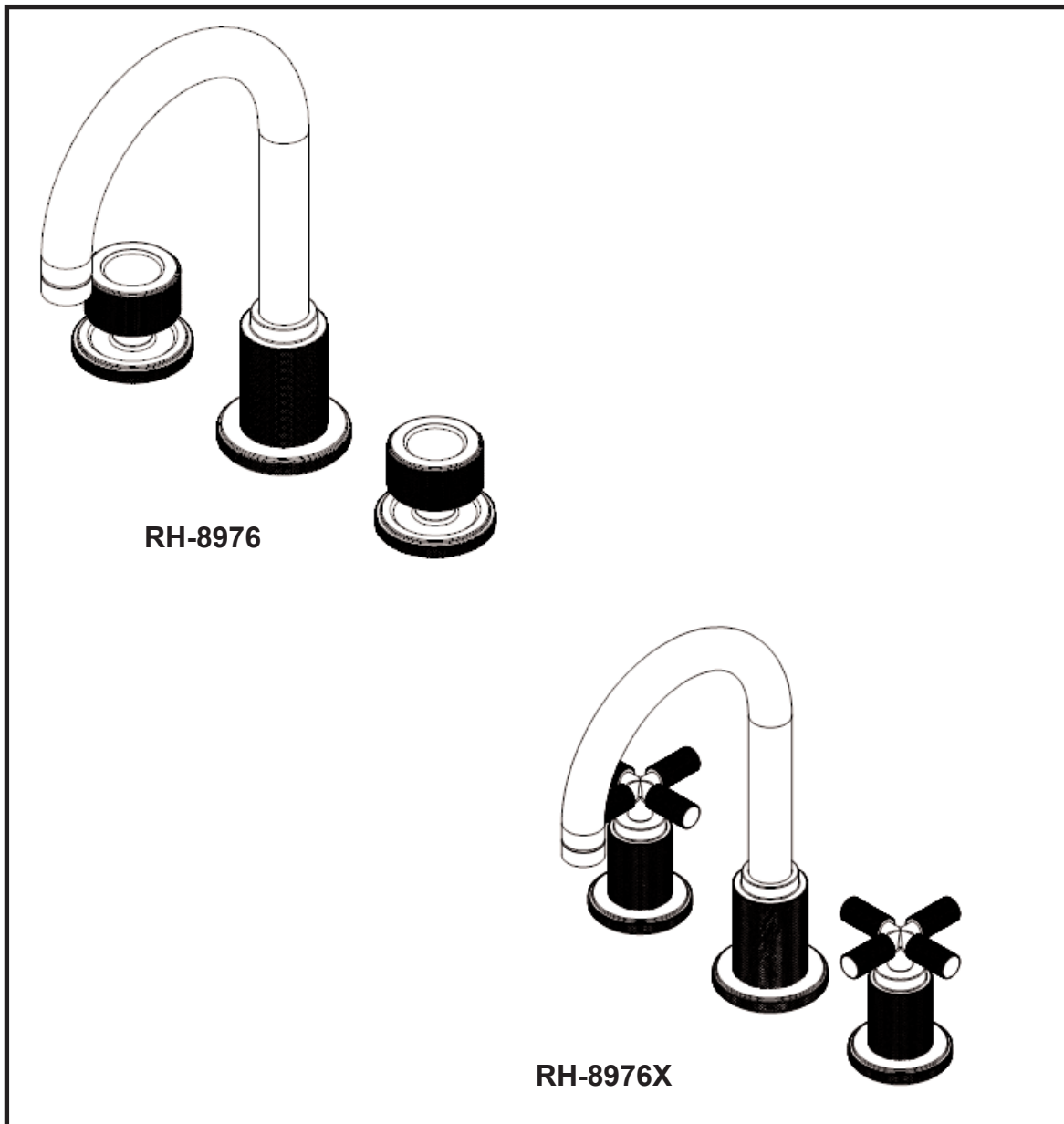

W/S LAV FAUCET
MODEL: KNURLED

RH-8976, RH-8971, RH-8976X, RH-8971X

Restoration Hardware Faucet Product Size Specification Diagram

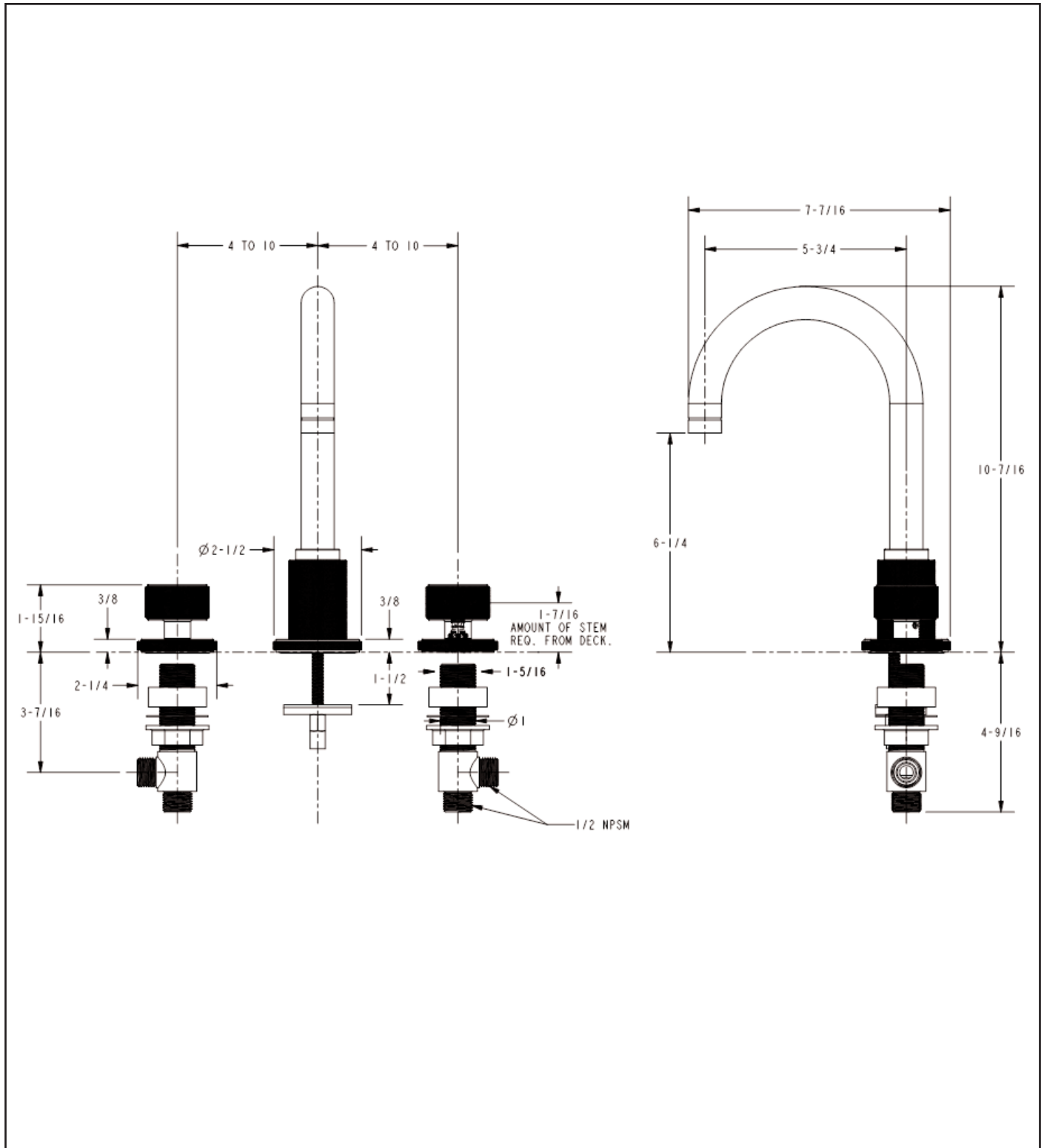

Recommended Deck Hole Size 1-3/8" Diameter
Dimensions are in Inches and Approximation of a Typical Installation

Common tools needed:

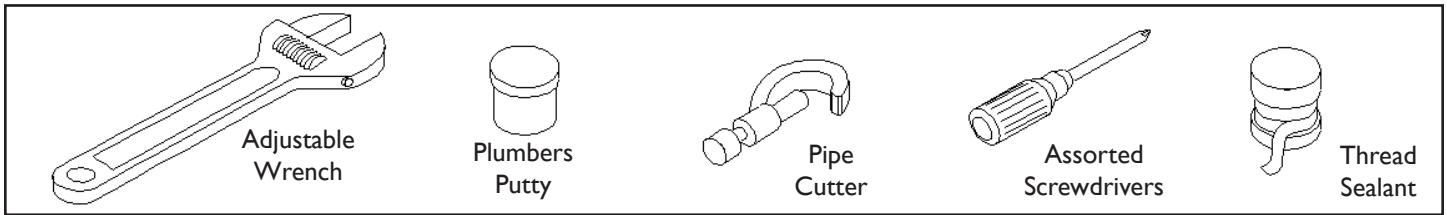

Installation Instructions

We Recommend Installation by a Licensed Plumbing Professional

I. Spout Assembly

- Insert HOSES (3) through O-RING (2), ESCUTCHEON (1) and sink hole. From underside of sink, Assemble MOUNTING NUT (6) MOUNTING CRESENT (5), and WASH-ER (8) onto SHANK (7) as shown. Align SPOUT (4) and secure into place by tightening mounting NUT (6).
- Connect the COLD & HOT VALVE assembly to the hoses coupling nuts (See step 3, page 4). Hand tighten and secure connection with a wrench 1/4 turn.

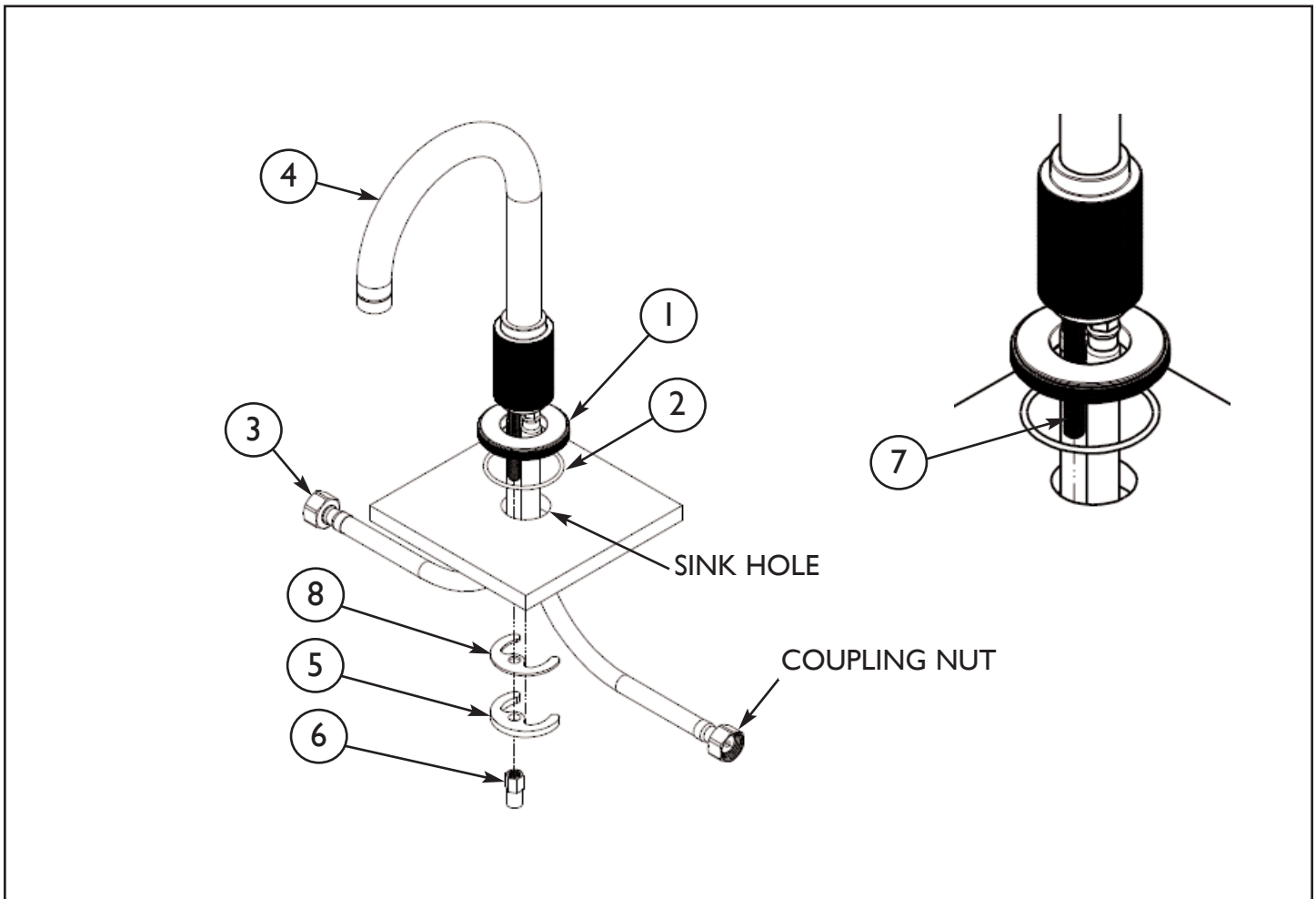

2. Valve Assembly

- Place FLANGE NUT (1) and INVERTED FLANGE NUT(2) onto valve BODY (4).
- Insert valve BODY (4) through sink hole from underside of sink. Valve BODY (4) should extend 1-7/16" above mounting surface. If necessary adjust lower flange NUT (1) and QUICK CONNECT SPACER (3).
- Set valve BODIES (4, 4A) so that their outlets are facing parallel with the SPOUT. Secure into place by tightening upper flange NUT (1).

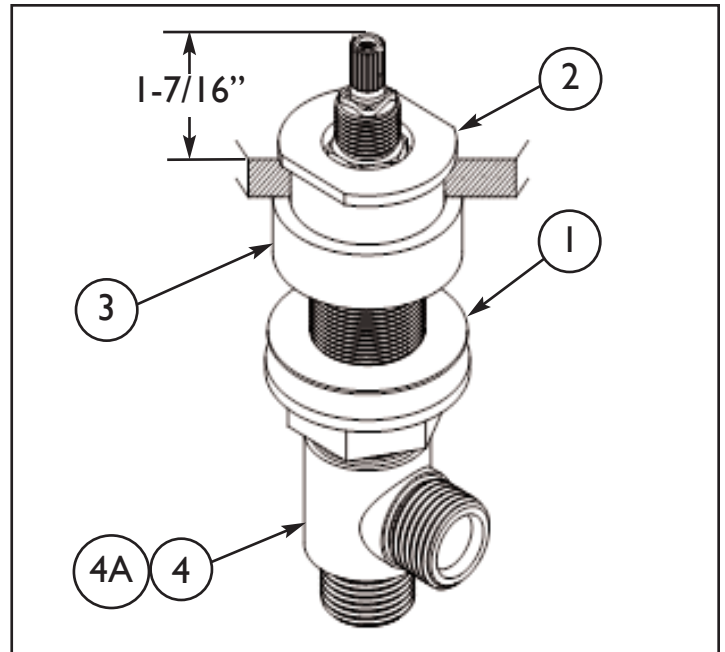

3. Hose and Valve Assembly

- Connect hoses coupling NUT (8) to outlet of each valve BODY (3).
- Hand tighten and secure each connection with a wrench 1/4 turn.

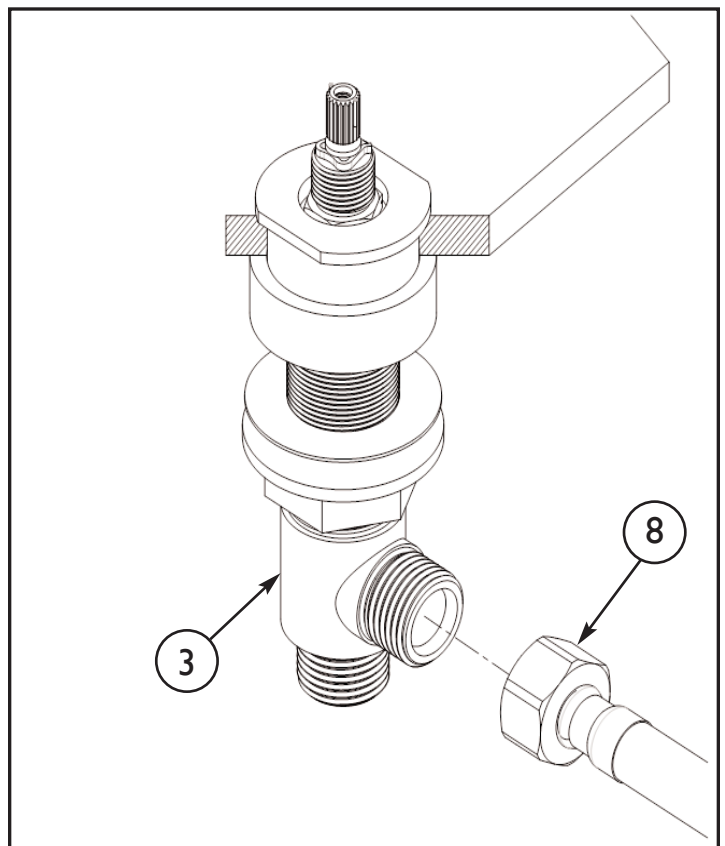

4. Make Water Supply Connections

NOTE: SUPPLY RISERS ARE SOLD SEPARATELY

- Connect water supply to VALVE BODIES (1, 1A) with one of the three following types of risers:
 - a. 1/2" IPS flexible RISER (2), discard rubber NOSECONE (7), friction WASHER (3) and coupling NUT (4).
 - b. 3/8" or 1/2" O.D. bullnose RISER (5), place friction WASH-ER (3) and coupling NUT (4) onto bullnose RISER (5).
 - c. 1/2" O.D. copper RISER (6), place coupling NUT (4), friction WASHER (3), and rubber NOSECONE (7) onto end of copper RISER(6).
- Use adjustable wrench to tighten connections. Do not over tighten and be careful not to kink copper supply when bending. Use a tube bender and cutter to properly adjust copper supply.

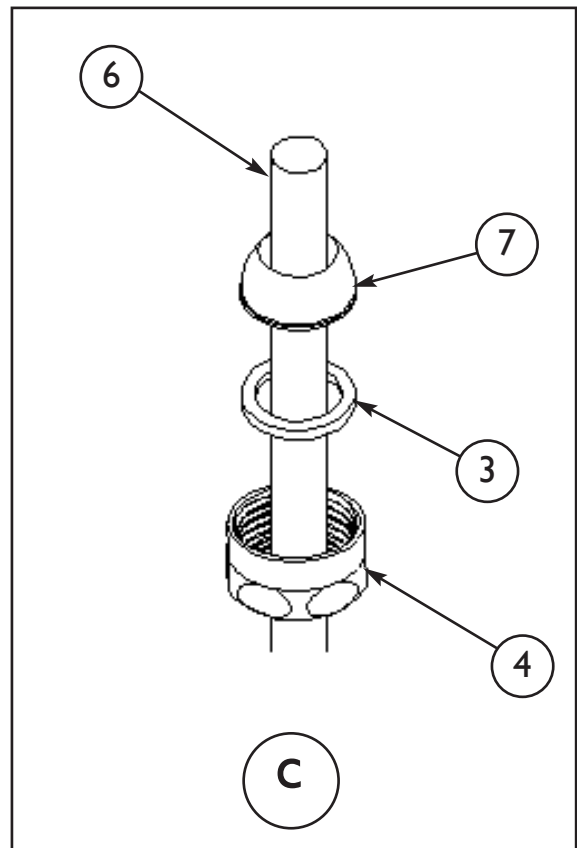
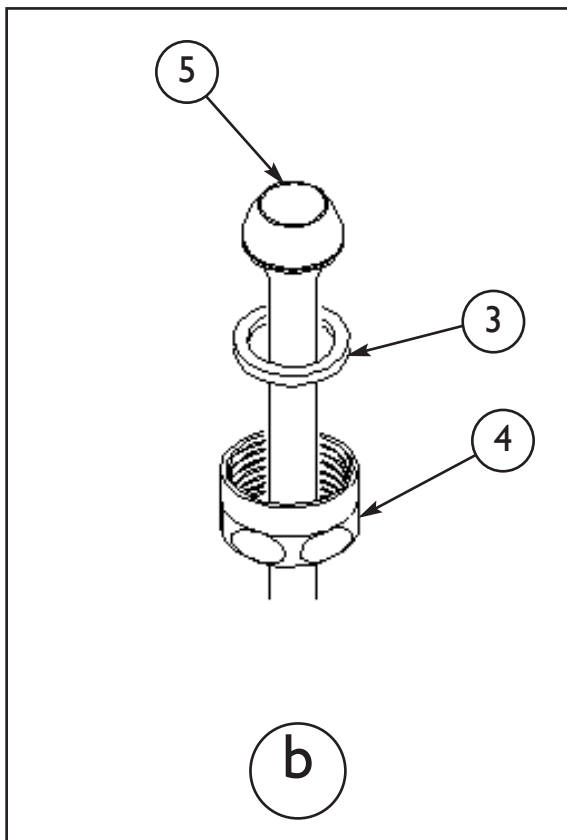
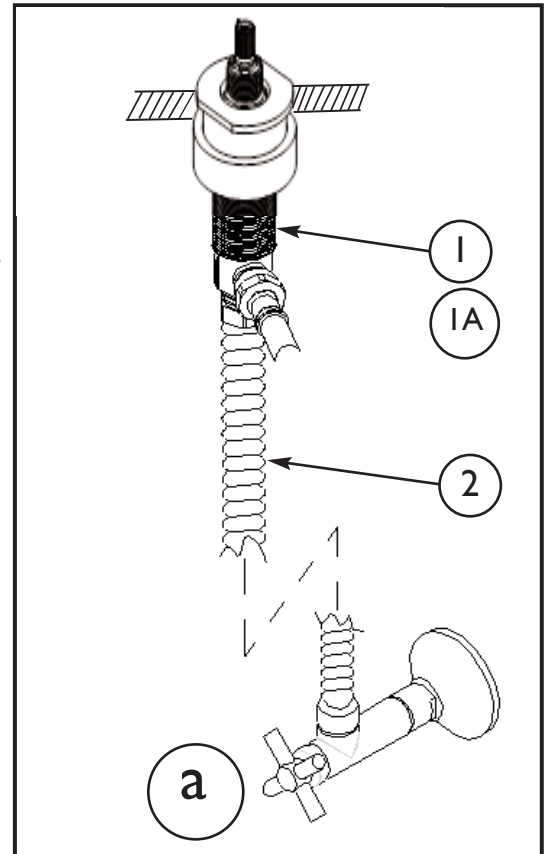

5. Install Handles

- Turn VALVE STEM (5) to OFF position.
- Tighten ESCUTCHEON (3) with O-RING (4) onto CARTRIDGE (6).
- Place HANDLE (1) into the VALVE STEM (5) and secure with SET SCREW (2). Any adjustments for rotational alignment must be made to the valve body, not to the cartridge.

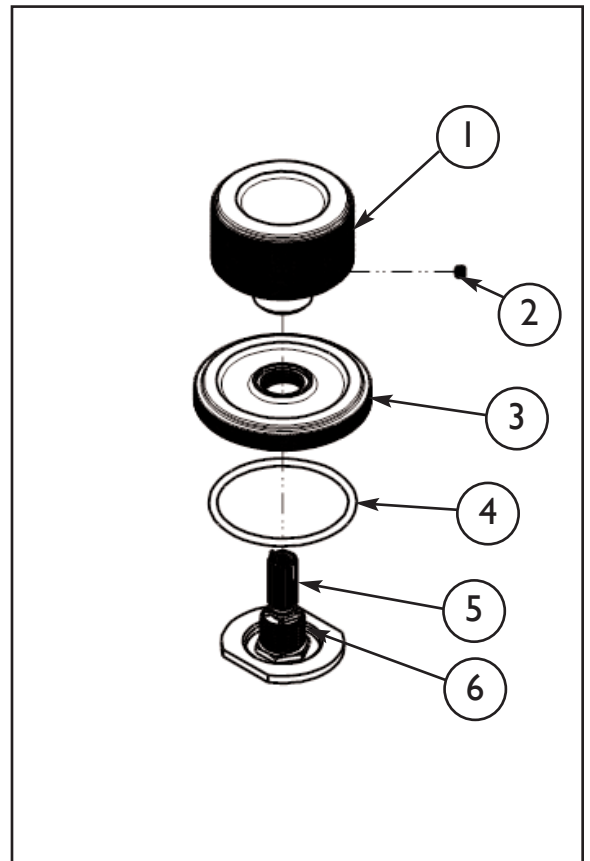

6. Install Drain

- Do not remove drain PLUG (1) from FLANGE (2). Place FLANGE (2) and white WASHER (3) through sink drain opening. (Clear silicone may be used in place of white washer.) From bottom side of sink, place cone shaped rubber WASHER (4) onto FLANGE (2) and slide up against sink bottom. Note: Cone portion of WASHER (4) to face upward. Next slide on clear flat WASHER (5) and secure with flange NUT (6). Assemble O-RING (7) to TAILPIECE (8) and attach to drain FLANGE (2). Attach TAILPIECE (8) to p-trap drain (9) (not included). See Figure 1.

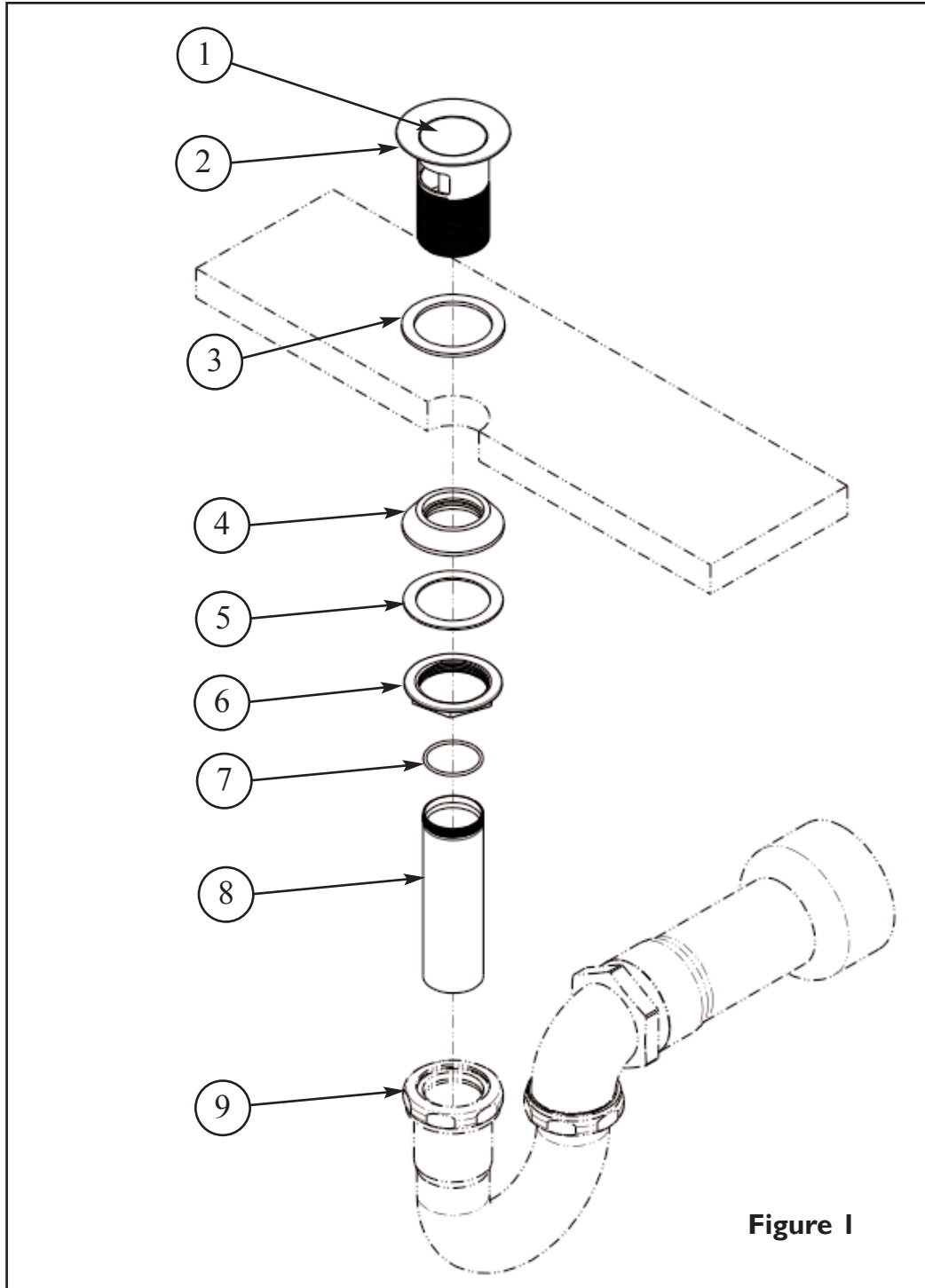

Figure 1

7. Test Installed Faucet

- With handles in OFF position, turn on water supplies and check all connections for leaks.
- Operate both handles to flush water lines thoroughly.
- Operate pop-up drain assembly and check for leaks.

Care and Cleaning

The lustrous finish on your Restoration Hardware Bathware fixture should be treated with care. Improper handling or cleaning can damage the surface of any metal finish. Use a soft cloth to wipe clean. Avoid harsh abrasive cleaner. Water contains lime and other mineral deposits that will be left on the surface after the water has evaporated. You can prevent these deposits from forming by always wiping the fixture dry immediately after use.

Technical Support and Customer Service

For technical support in the installation of your Restoration Hardware Bathware fixture, please call 1-866-417-5207 weekdays between the hours of 7:00am and 4:00pm PST.

For other questions regarding your order, to order additional components of the Restoration Hardware Bathware Collection, to order replacement parts, or to address warranty issues, please contact Restoration Hardware Customer Service at 1-877-747-4671.