

2 & 3 Port In Wall Diverter

Installation Instructions

Model No. RH-5446



Recommended Installation by a Professional Plumbing Contractor

NOTE: Use Teflon tape or equivalent to seal all threaded port joints.

Warning: To prevent severe damage to valve body, any solder/braze process must be performed a min. of 4" from ports, otherwise cartridge **must** be removed from valve body.

- Valve supplied in 3-way mode; 2-way Washer supplied separately.
- To change to 2-way mode, remove All-thread, Stem and Diverter Nut. See **Figure 1**. Otherwise proceed to step 4. Select the appropriate 2 or 3-way Washer and orientation for your application, per Diagram 2a, 2b or 2c, and place onto cartridge.
- **2a or 2b.** 2-way is used for 2 end devices, a 1/2 NPT Cap is required on the unused "OUT" port. Connect end device lines to "OUT" ports 1 & 2 or 1 & 3. Unused "OUT" port CAN NOT be used as shut off.
- **2c.** 3-way is used for 3 end devices. Connect end device lines to "OUT" ports 1, 2 & 3.
- Re-assemble Diverter Nut, Stem and All-thread.
- Diverter is used with a mixed (hot & cold) input, (ie Balance Pressure or Thermo Valve), connect supply to "IN" port only.
- Connect end devices to "OUT" ports

Note: Do not cut Stem and All-thread nipple until finished wall is complete and dimension check of Handle and Escutcheon/Bonnet trim is done. (Stem groove @ 1/2" intervals.)

- The stem must be trimmed to 2" from finished wall.
- Cut All-thread 15/16" shorter than stem.
- Place escutcheon over nipple, thread bonnet onto all thread. Place handle onto valve stem, then thread screw to secure. Press cap into top of handle. Adjustments for rotational alignment can be made by changing the position of stem on cartridge.
- Turn on water supply.
- **Note:** To achieve desired Handle rotational alignment, the Stem **MUST** be removed from Diverter body and repositioned on the Cartridge Stem.

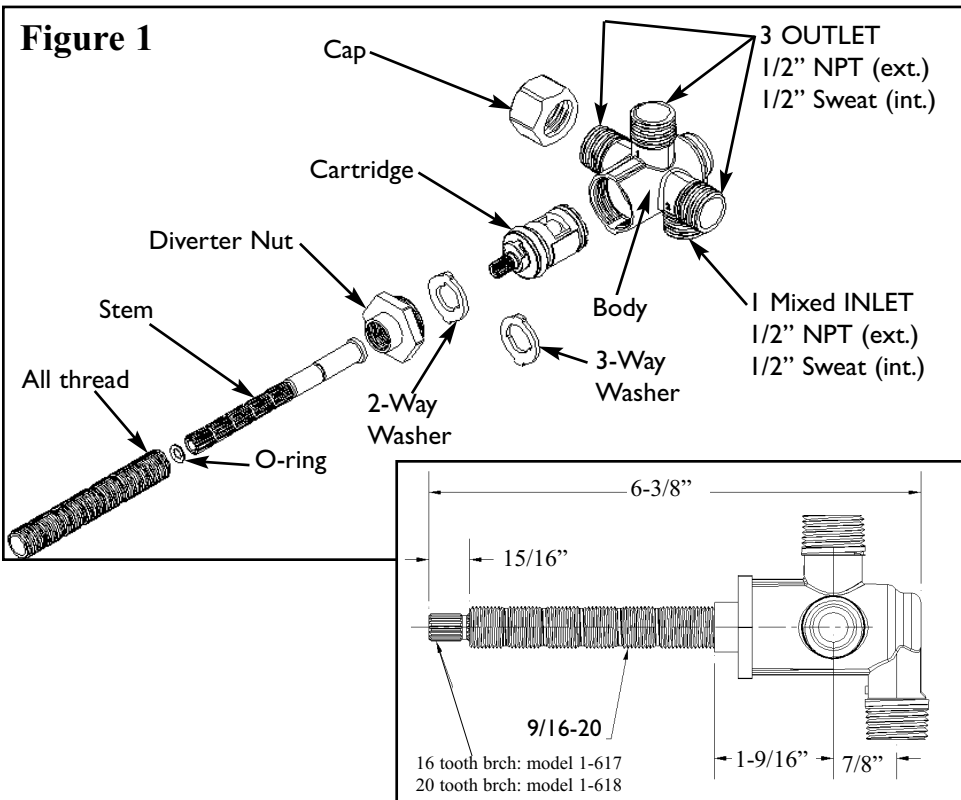
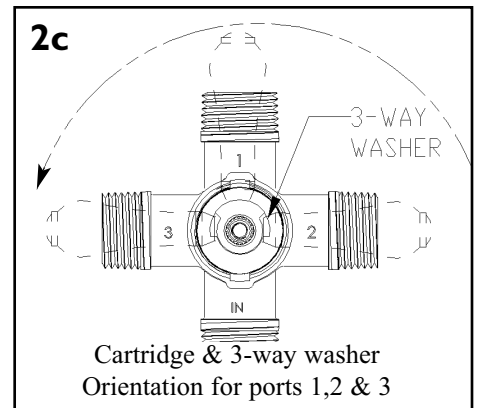
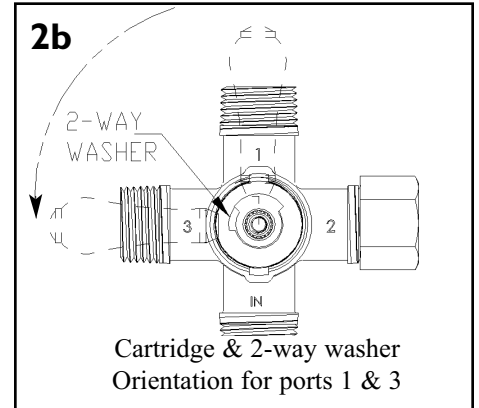
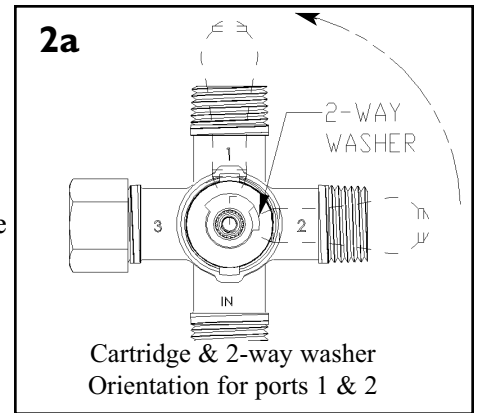

Care and Cleaning

The lustrous finish on your Restoration Hardware Bathware fixture should be treated with care. Improper handling or cleaning can damage the surface of any metal finish. Use a soft cloth to wipe clean. Avoid harsh abrasive cleaner. Water contains lime and other mineral deposits that will be left on the surface after the water has evaporated. You can prevent these deposits from forming by always wiping the fixture dry immediately after use.

Technical Support and Customer Service

For technical support in the installation of your Restoration Hardware Bathware fixture, please call 1-866-417-5207 weekdays between the hours of 7:00am and 4:00pm PST.

For other questions regarding your order, to order additional components of the Restoration Hardware Bathware Collection, to order replacement parts, or to address warranty issues, please contact Restoration Hardware Customer Service at 1-877-747-4671.