

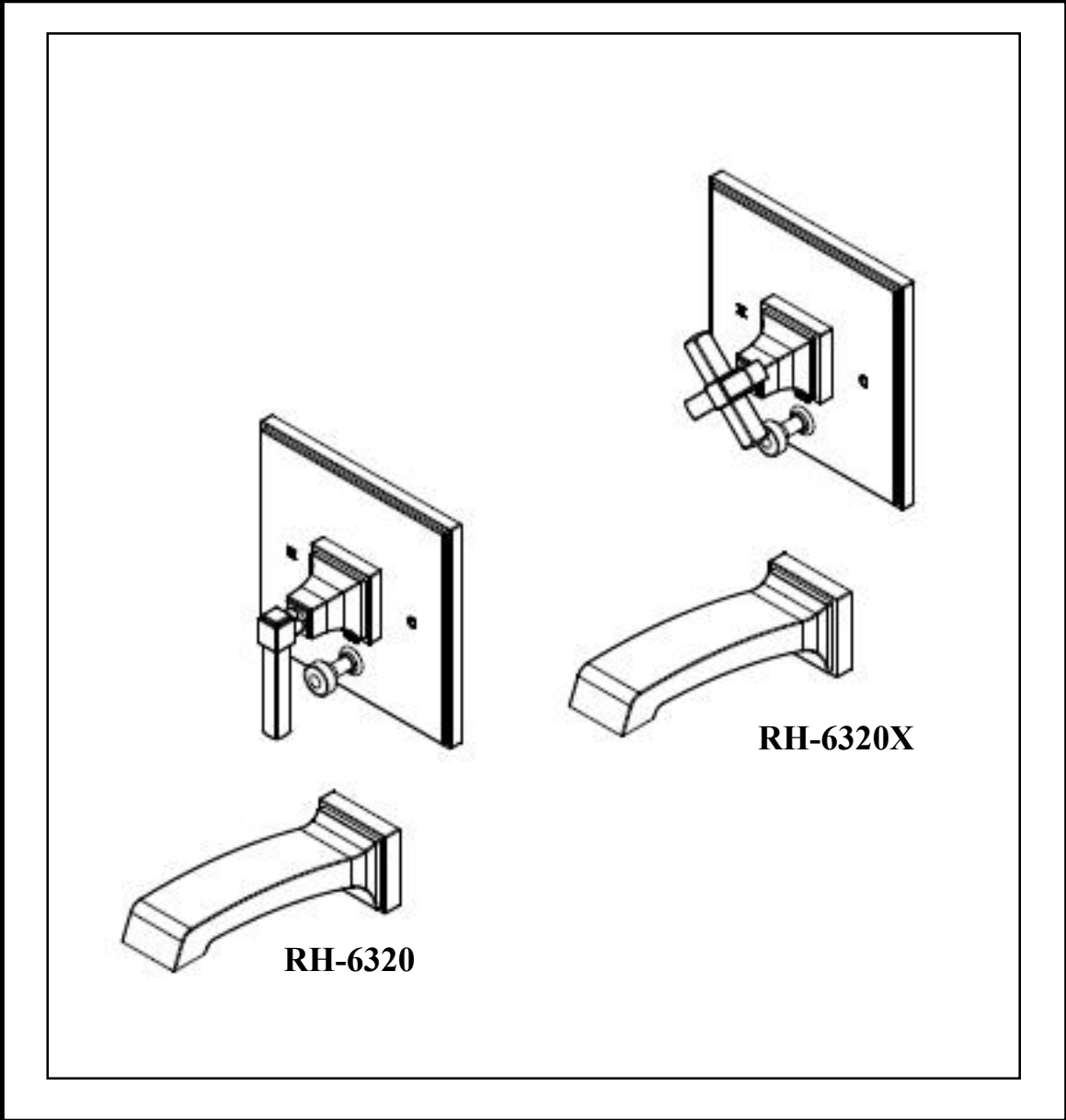

INSTALLATION INSTRUCTIONS



MODEL: Dillon

RH-6320
RH-6320X

Restoration Hardware Balance Pressure Tub /Shower Set Specification Diagram

SPECIFICATIONS

Min. Operating pressure: 20 psi [140 KPa]
 Max. Operating pressure: 125 psi [860 KPa]
 Max. Burst pressure: 500 psi [3450 KPa]
 Max. Hot water temp: 110°F [40°C]

Flow rate in USGPM [l/min] @ 50 psi [345 KPa].

	Tub	Shower
1/2 Diverter (optional):	6.5 [25]	5.3 [20]

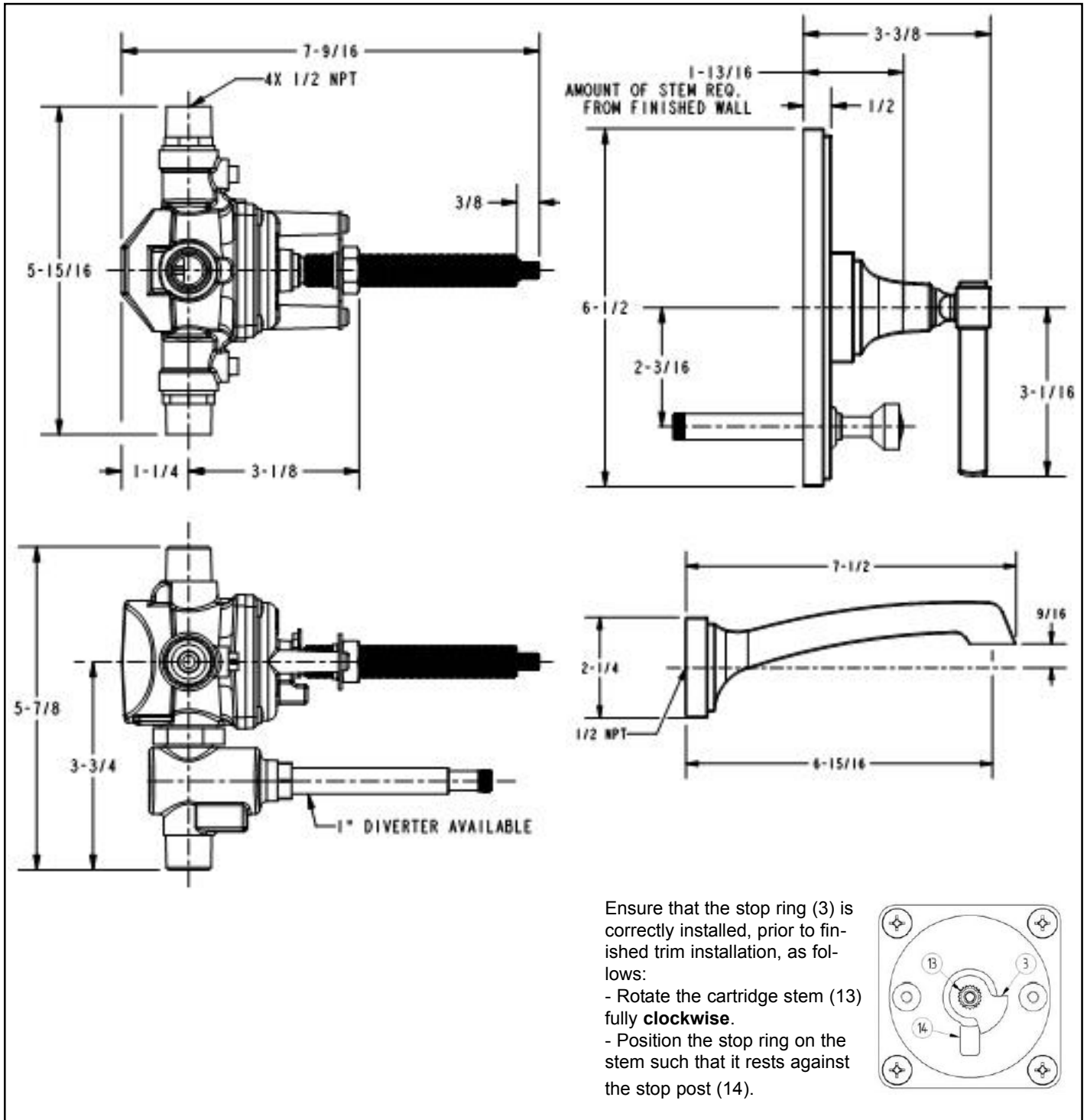

All Threaded Connections are $\frac{1}{2}$ " NPT

Dimensions are in Inches and Approximation of a Typical Installation

Common tools needed:

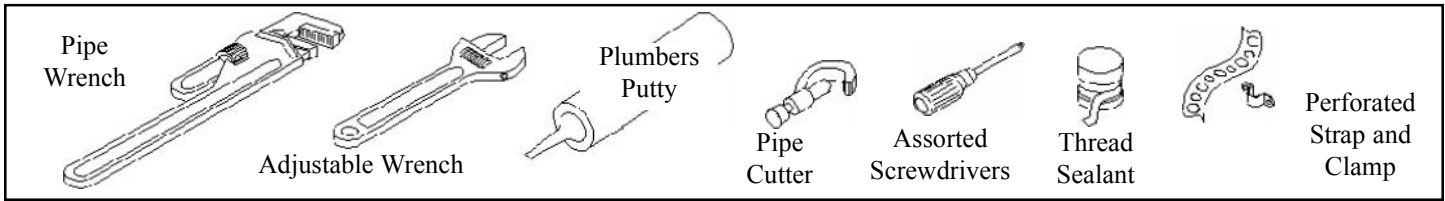

Installation Instructions

We Recommend Installation by a Licensed Plumbing Professional

1. Valve Assembly

- Position VALVE (1) with the “S” in the up position
- The VALVES (1) 1/2 NPT inlets are colored blue for COLD SUPPLY (2) and red for HOT SUPPLY (3).
- Apply thread sealant to the supply fittings and firmly tighten into VALVE (1) inlets. Under normal soldering conditions the removal of inlet filter/seat and mixing cartridge is not necessary; however, if brazing and / or induction heating is used removal is required. Whenever possible, it is best to perform all solder/brazing operations on piping prior to attachment to VALVE (1).
- VALVE (1) and / or SUPPLY (2,3) must be secured to CROSS BRACE (4) using PERFORATED STRAP (5) or equivalent.
- Position VALVE (1) to finished wall as mentioned on specification diagram.
- Apply thread sealant to SHOWER RISER (6) and attach to VALVE (1) outlet port marked “S”.
- Secure SHOWER RISER (6) to CROSS MEMBER (4) using PERFORATED STRAP (5) or equivalent.
- Apply thread sealant to TUB SUPPLY (7) and attach to VALVE (1) outlet port marked “T”.
- Secure TUB SUPPLY (7) to CROSS MEMBER (4) using PERFORATED STRAP (5) or equivalent.
- Apply PLUG (8) for test. Turn on both water supplies to valve and check for leaks. Note: Water pressure *must* be applied to both hot and cold inlet ports for proper valve operation.
- After inspection turn off water supply

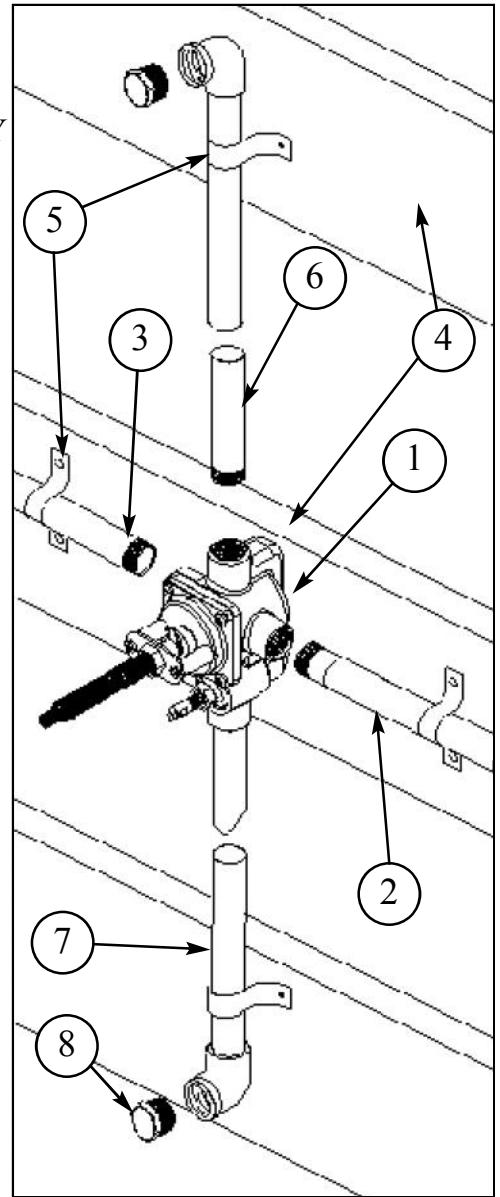

2. Setting The Temperature Limit Stop

- Remove the all-thread NIPPLE (1) and RETAINING SCREWS (2) RETAINING PLATE (4) and STEM (5) from the valve COVER (9).
- Remove the LIMIT STOP (6) see figure 2. Do not remove the MECHANICAL STOP (7). (If for any reason the MECHANICAL STOP (7) is removed refer to **Cartridge Removal and Replace** section below.)
- From the CLOSED position, rotate the CARTRIDGE STEM (10) counter-clockwise until the desired temperature is achieved.
- Place the LIMIT STOP (6) on the CARTRIDGE STEM (10) against the STOP BLOCK (15) located on COVER (9). Rotate the CARTRIDGE STEM (10) several times to make sure the stop is at the desired temperature setting.
- Replace the STEM (5), RETAINING PLATE (4) and RETAINING SCREWS (3) and all-thread NIPPLE (1) onto valve COVER (9). (NOTE: For stem to be fully seated into cartridge, all-thread nipple and locking nut must be tightly secured against retaining plate.)
- Proceed to the VALVE TRIM INSTALLATION.

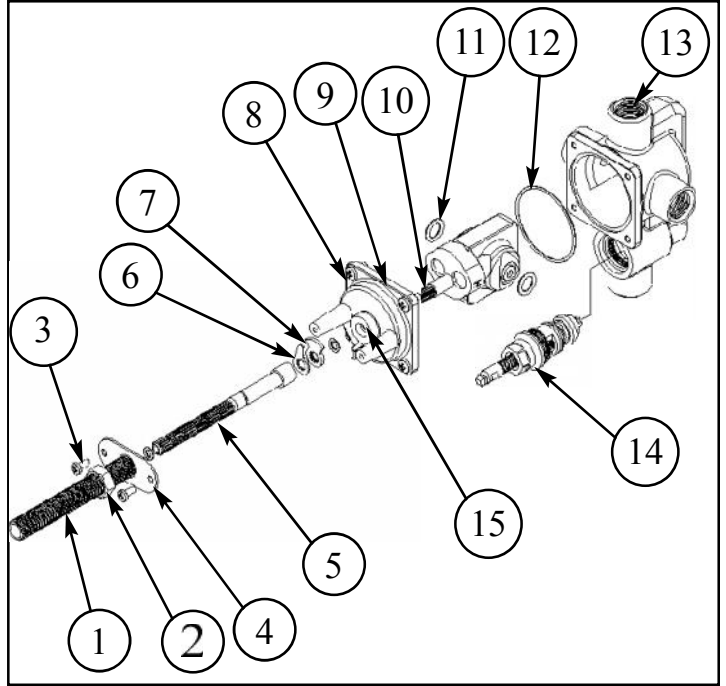

2a. Cartridge Removal And Replacement

- Remove the all-thread NIPPLE (1), RETAINING SCREWS (3), RETAINING PLATE (4) and STEM (5) from the valve COVER (9).
 - Remove the LIMIT STOP (6) and MECHANICAL STOP (7)
 - Remove the COVER SCREWS (8), COVER (9) and cover O-RING (10).
 - Carefully slide the CARTRIDGE (10) out of valve BODY (13). (If filter removal is necessary refer to **Cleaning the Filter** described in Trouble Shooting Section.)
 - Replace CARTRIDGE (10) ensuring that the cartridge's O-RINGS (11) are in place and lubricated with plumbers (non-petroleum) grease. The "H" and "C" on the side of the CARTRIDGE (10) indicates the cartridges proper orientation to the appropriate inlet supply line.
 - Once the CARTRIDGE (10) is installed, it is very important to confirm that the cartridges rear posts are correctly locked into the BODY (13) mating hole.
 - Replace the cover O-RING (12), COVER (9) and tighten COVER SCREWS (8) firmly into place.
 - To set the MECHANICAL STOP (7) rotate clockwise the CARTRIDGE STEM (10) until it stops.
- Warning: Do Not forcefully rotate stem closed.**
- Place the MECHANICAL STOP (7) onto CARTRIDGE STEM (10) as shown in figure 1.
 - Replace LIMIT STOP (6) as described above in **Setting the Temperature Limit Stop**.

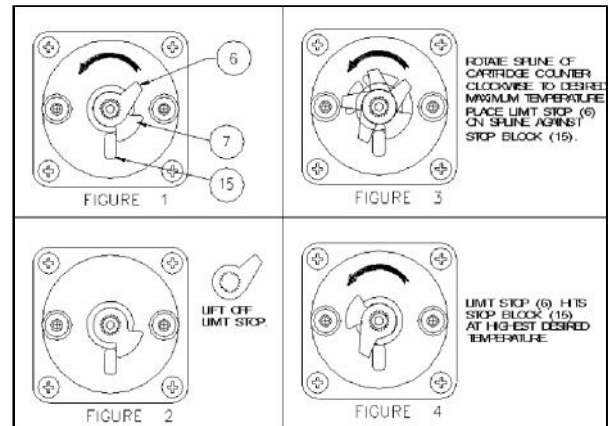

3. Valve Trim Installation

(Perform these steps after finished wall has been completed)

- The STEM (3) must be trimmed to 1-13/16" from finished wall. Remove STEM (3) by loosening NUT (2) and removing NIPPLE (1), NUT (2) and STEM (3). Trim STEM (3) to previously mentioned dimension.
- The NIPPLE (1) must be trimmed 3/8" less than STEM (3).
- Fasten STEM (3) and NIPPLE (1) onto VALVE (4). Use NUT (2) to lock NIPPLE (1) into place. Rotate STEM (3) to ensure there is no binding. If binding, loosen NIPPLE (1) until STEM (3) moves freely and does not wobble.
- Place diverter trim LINK (6) and POST (7) onto valve's DIVERTER (5).
- Tighten diverter trim SLEEVE (9) onto DIVERTER (5).
- Align cover PLATE (8) and slide onto valve NIPPLE (1) and diverter SLEEVE (9). (Soapy water will improve sliding of rubber seal onto diverter sleeve.)
- Insert O-RING (13) into the backside of ESCUTCHEON (11) and place over NIPPLE (1) and flush against cover PLATE (8). Secure HANDLE (12) by first engaging the STEM (3). Any adjustments for rotational alignment must be made by tightening cartridge. **DO NOT** loosen cartridge. Factory torque of 14 ft.lbs. must be maintained.
- Tighten diverter KNOB (10) onto POST (7).

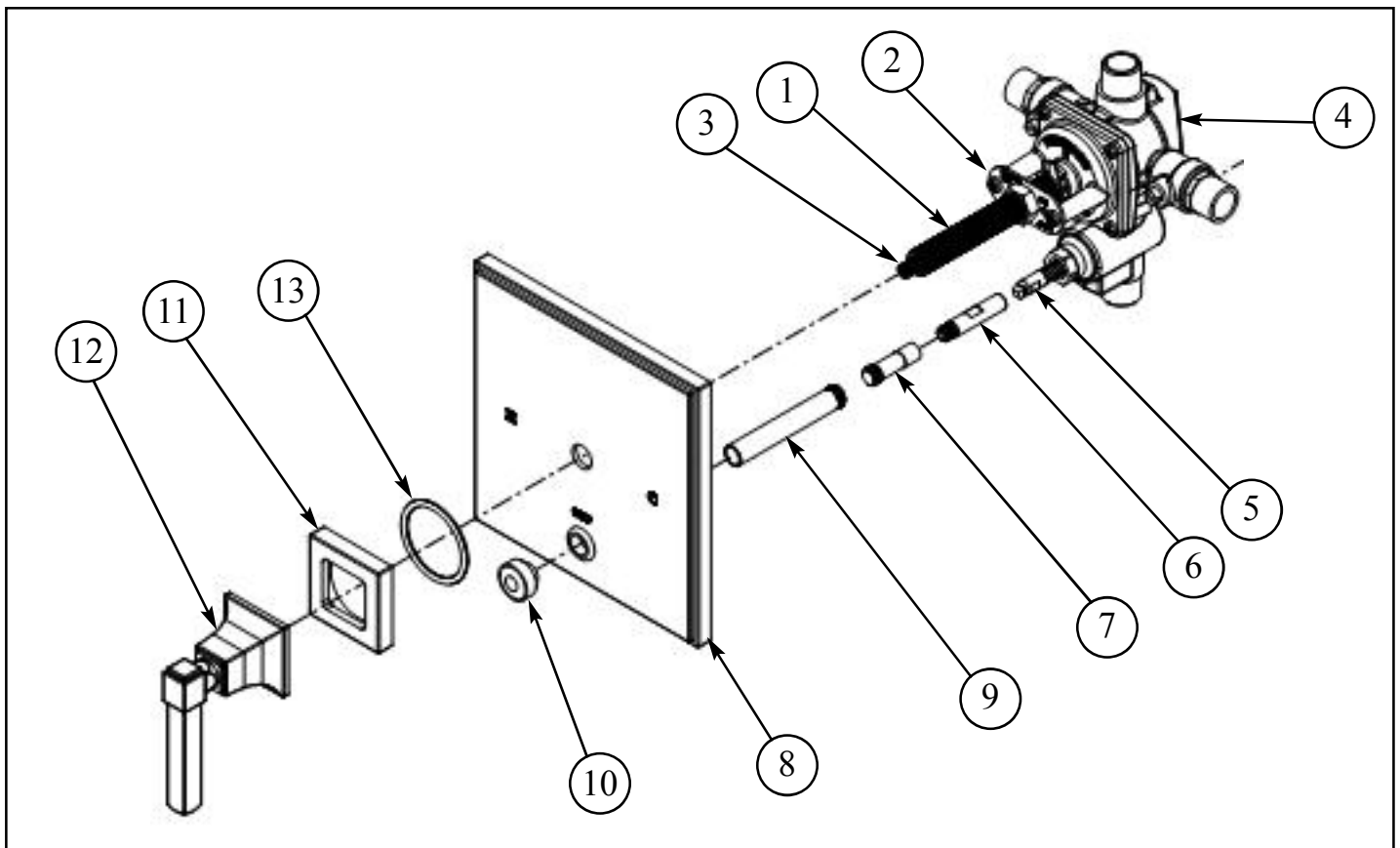

4. Tub Spout Installation

- Place base RING (2) onto bottom of SPOUT (1).

Based on finished wall thickness select appropriate size 1/2" NPT NIPPLE (3) for SPOUT

- (1) installation.
Note: NIPPLE (3) is not included.

- Apply thread sealant to both ends of NIPPLE (3) and thread into fitting inside finished wall.

- Attach SPOUT (1) to protruding NIPPLE (3) and secure into place.

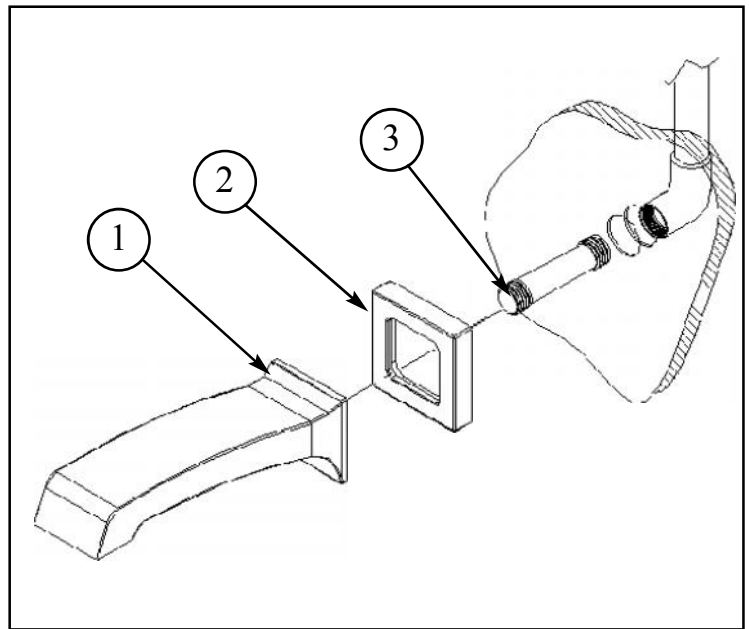

5. Test Installed Tub / Shower Set

- Turn on the shower valve by rotating the handle counter-clockwise. Water will start to flow from the tub spout.
- Pull the diverter knob to operate the showerhead.
- Water mixing temperature to handle rotation is as follows:
 - 1/4 to 1/2 = warm
 - 1/2 to 3/4 = hot
- 0 to 1/4 = cold
- 1/4 to 1/2 = warm
- 1/2 to 3/4 = hot

6. Trouble Shooting

MALFUNCTION	CAUSE	REMEDY
Opening immediately to hot water.	Hot and cold water supplies have been connected in reverse.	Rotate cartridge (See Page 4, Item no.2a)
Water drips after shutting off the valve.	Residual water in valve and piping. Incorrect setting of the mechanical stop against the stop block causing a partially opened cartridge. O-ring seal on the inlet of the cartridge is faulty or seal assembly is damaged.	Allow approximately 3-3 minutes to drain. Reset the mechanical stop. (See Page 4, Item no. 2a) Check the O-ring & seal for cuts or overheating damage during installation. Replace if necessary.
Water insufficiently hot.	Adjustable handle position stop incorrectly set.	Refer to the instruction on "Setting Temperature Limit Stop."
Valve body too deep into wall.	The measured rough in or finished wall surface is incorrect.	Reset the valve.
No or low flow of hot or cold water.	Either the hot or cold side is not fully pressurized. Debris caught inside the inlet of cartridge. Debris caught inside filter or inlet ports.	Verify that all service stops for both the hot and cold are fully open and pressurized. Remove the cartridge (See Page 4). If debris is lodged in the inlet check valve, the white poppet will be stuck in the open (down) position. The debris can be removed with a straightened paper clip or fine wire. Gently insert the wire and move it in a circular motion to dislodge any debris. Remove cartridge and follow Figures 5 thru 8 below.

* **WARNING:** At no time try to stop dripping by applying extreme force or overtightening the handle.

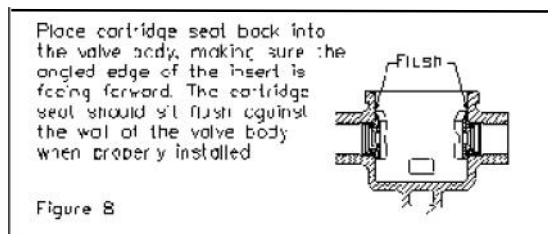
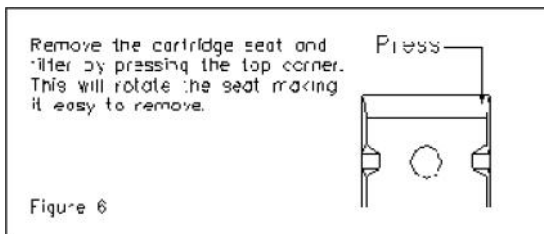
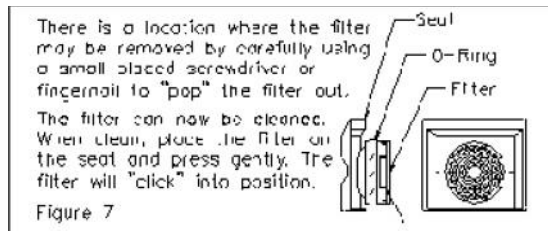
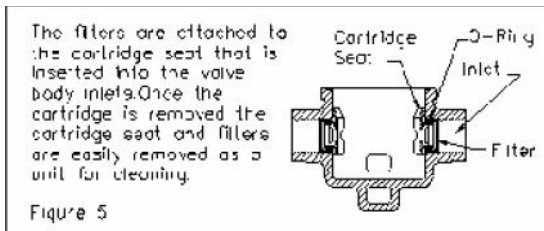

Care and Cleaning

The lustrous finish on your Restoration Hardware Bathware fixture should be treated with care. Improper handling or cleaning can damage the surface of any metal finish. Use a soft cloth to wipe clean. Avoid harsh abrasive cleaner. Water contains lime and other mineral deposits that will be left on the surface after the water has evaporated. You can prevent these deposits from forming by always wiping the fixture dry immediately after use.

Technical Support and Customer Service

For technical support in the installation of your Restoration Hardware Bathware fixture, please call 1-866-417-5207 weekdays between the hours of 7:00am and 4:00pm PST.

For other questions regarding your order, to order additional components of the Restoration Hardware Bathware Collection, to order replacement parts, or to address warranty issues, please contact Restoration Hardware Customer Service at 1-877-747-4671.