

Installation Instructions

3/4" STOP VALVE /
VOLUME CONTROL
Model No. 23690023 (RH-5745)

RESTORATION
HARDWARE

Recommended Installation by a Professional Plumbing Contractor

Note: Use Plumbers tape or equivalent to seal all threaded port joints.

Warning: To prevent severe damage to valve, any solder/braze process must be performed a min. of 4" from ports. These valves may be used as stop & volume controlling valves between water source and end output device. Typical usage is between thermo valve and multiple output devices (eg. Showerhead, body sprays, handshowers, etc...).

I. Valve Installation

- Attach supply source to inlet of valve. Water flow direction is indicated by "ARROW" on side of body.
- Attach end device to outlet of valve.
- Position valve in wall as shown in fig. I. These dimensions are for typical installations. If thick finished wall materials are to be used in construction, it is recommended that valve is position toward outer face of stud.
- Support valve and/or piping to stud framing using strap tape or equivalent.
- Turn on water supply and inspect for leaks.

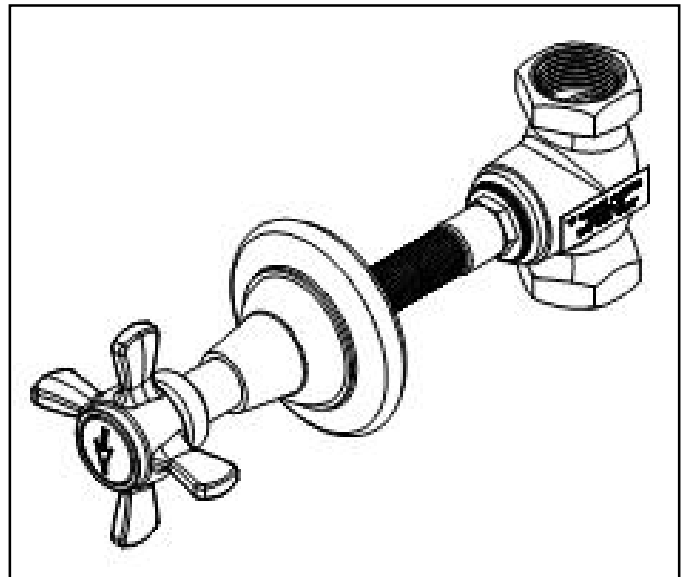

2. Trim Installation

1. Install ESCUTCHEON/BONNET and BASE RING trim pieces onto CARTRIDGE ALL-THREAD NIPPLE flush against Finished Wall. Mark the CARTRIDGE ALL-THREAD NIPPLE where excess needs to be trimmed.
 2. The stem must be trimmed to 2-3/4" from finished wall.
 3. The nipple must be trimmed 1/2" shorter than stem.
 4. Remove the ADAPTER SCREW and temporarily install HANDLE onto CARTRIDGE ADAPTER and measure DISTANCE between top of ESCUTCHEON/BONNET and bottom of HANDLE.
 5. Disassemble HANDLE, ESCUTCHEON/BONNET, BASE RING, and CARTRIDGE ADAPTER to trim SUM (SUM= DISTANCE + 1/16") from the 20 tooth CARTRIDGE STEM length.
Note: For some HANDLE styles, where portion of HANDLE base inserted inside ESCUTCHEON/BONNET, additional CARTRIDGE STEM trim is needed to achieve desired aesthetic look.
- * If finished wall material is thicker than "Mud/Tile max" stated, then the "Face of stud" dimension must be less than shown.

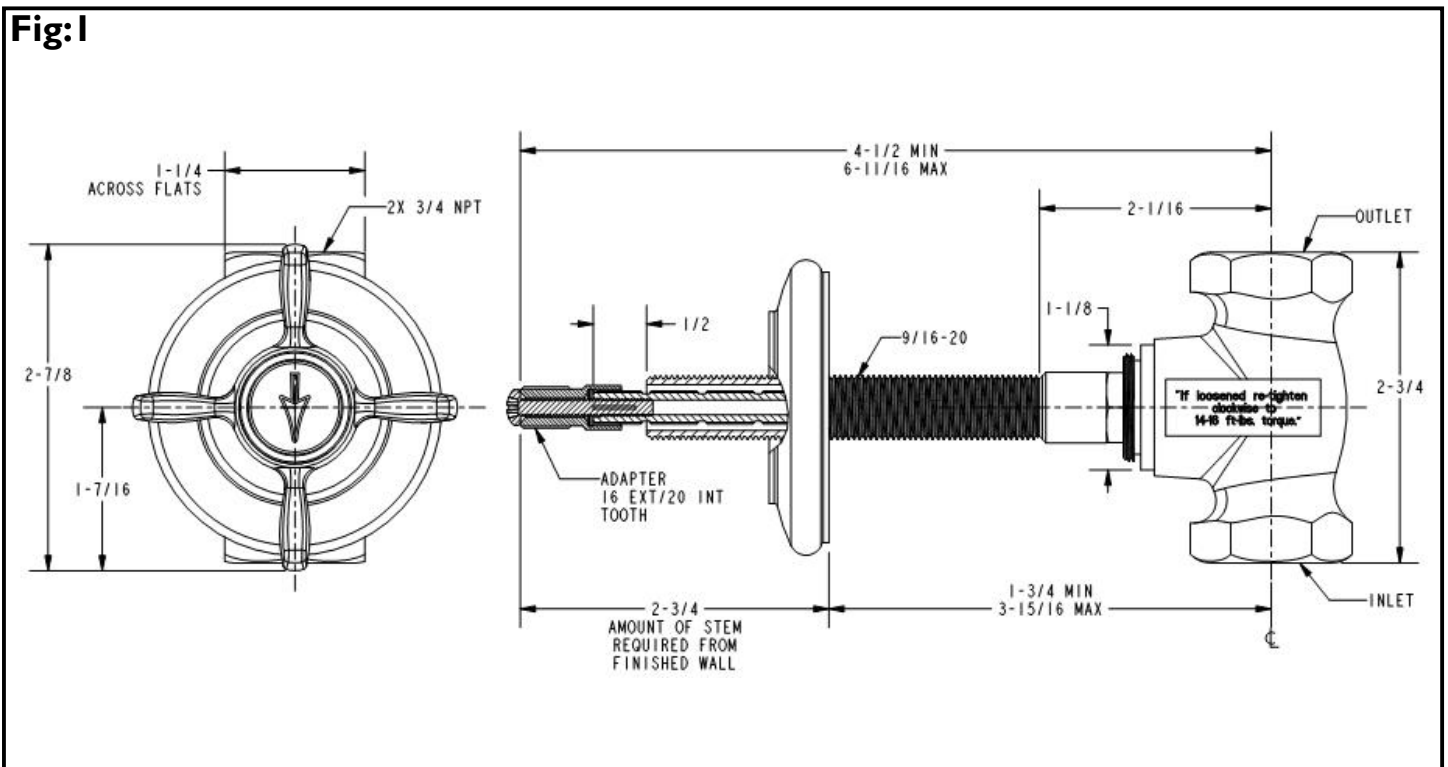

3. Handle Adjustment

1. Ensure cartridges in full closed position, use previously removed ADAPTER SCREW to loosely install CARTRIDGE ADAPTER onto 20 tooth CARTRIDGE STEM. Temporary install the HANDLE and check alignment.
2. If the HANDLE lever is not correctly aligned, remove HANDLE, loosen up (but do not completely remove) the ADAPTER SCREW and rotate CARTRIDGE ADAPTER one tooth clockwise (18 degrees), reassemble the HANDLE and recheck alignment. Repeat until HANDLE is aligned.
3. Remove HANDLE from CARTRIDGE ADAPTER (**Importance:** do not remove the CARTRIDGE ADAPTER from CARTRIDGE STEM). Tighten the ADAPTER SCREW to firmly secure CARTRIDGE ADAPTER to cartridge. Reattach HANDLE to CARTRIDGE ADAPTER and secure in place with set screw(s). **Note:** When reattaching HANDLE, assure a small gap between HANDLE and ESCUTCHEON/BONNET to prevent metal to metal contact.

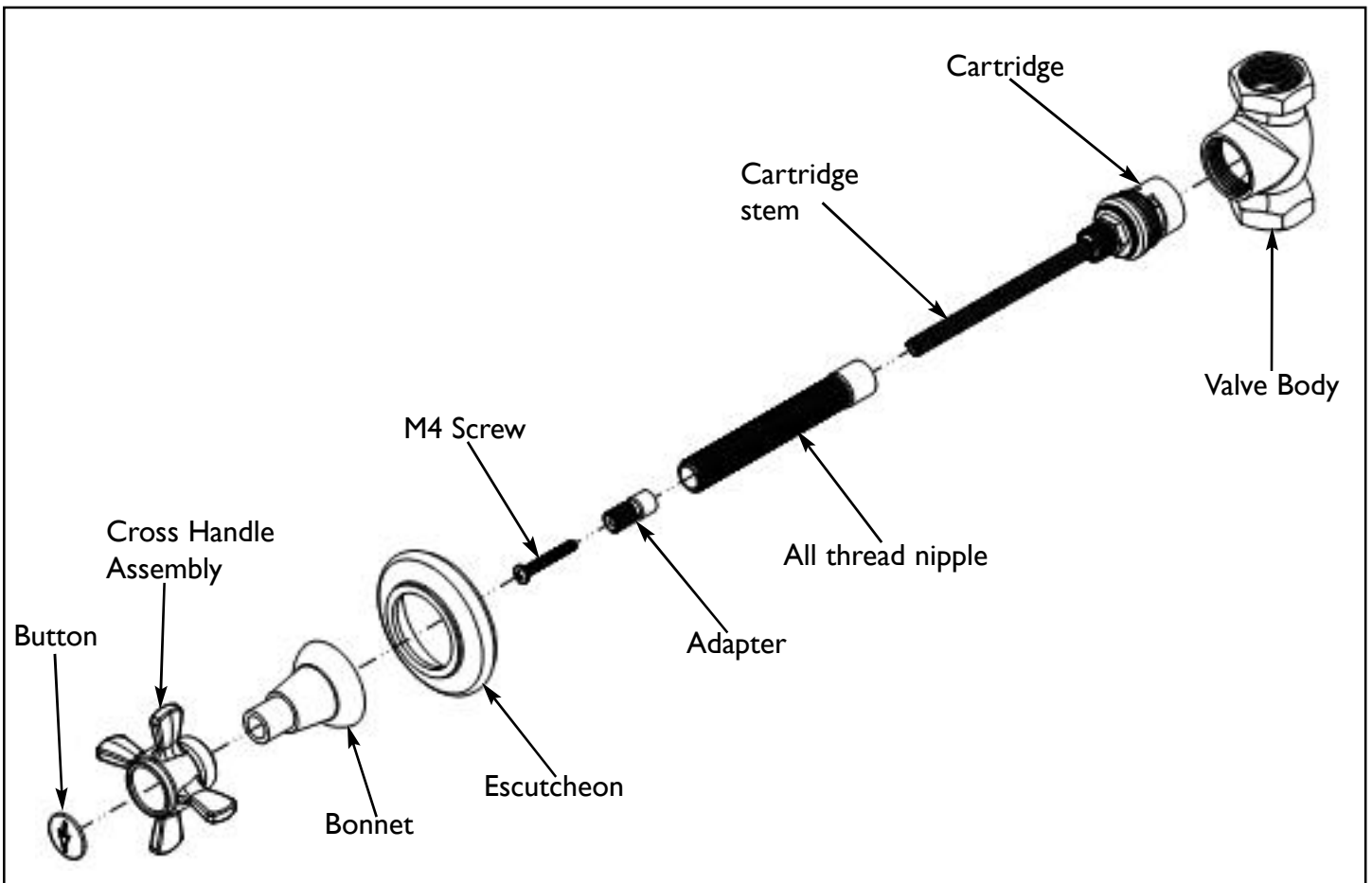

Care and Cleaning

The lustrous finish on your Restoration Hardware Bathware fixture should be treated with care. Improper handling or cleaning can damage the surface of any metal finish. Use a soft cloth to wipe clean. Avoid harsh abrasive cleaner. Water contains lime and other mineral deposits that will be left on the surface after the water has evaporated. You can prevent these deposits from forming by always wiping the fixture dry immediately after use.

Technical Support and Customer Service

For technical support in the installation of your Restoration Hardware Bathware fixture, please call 1-866-417-5207 weekdays between the hours of 7:00am and 4:00pm PST.

For other questions regarding your order, to order additional components of the Restoration Hardware Bathware Collection, to order replacement parts, or to address warranty issues, please contact Restoration Hardware Customer Service at 1-877-747-4671.