

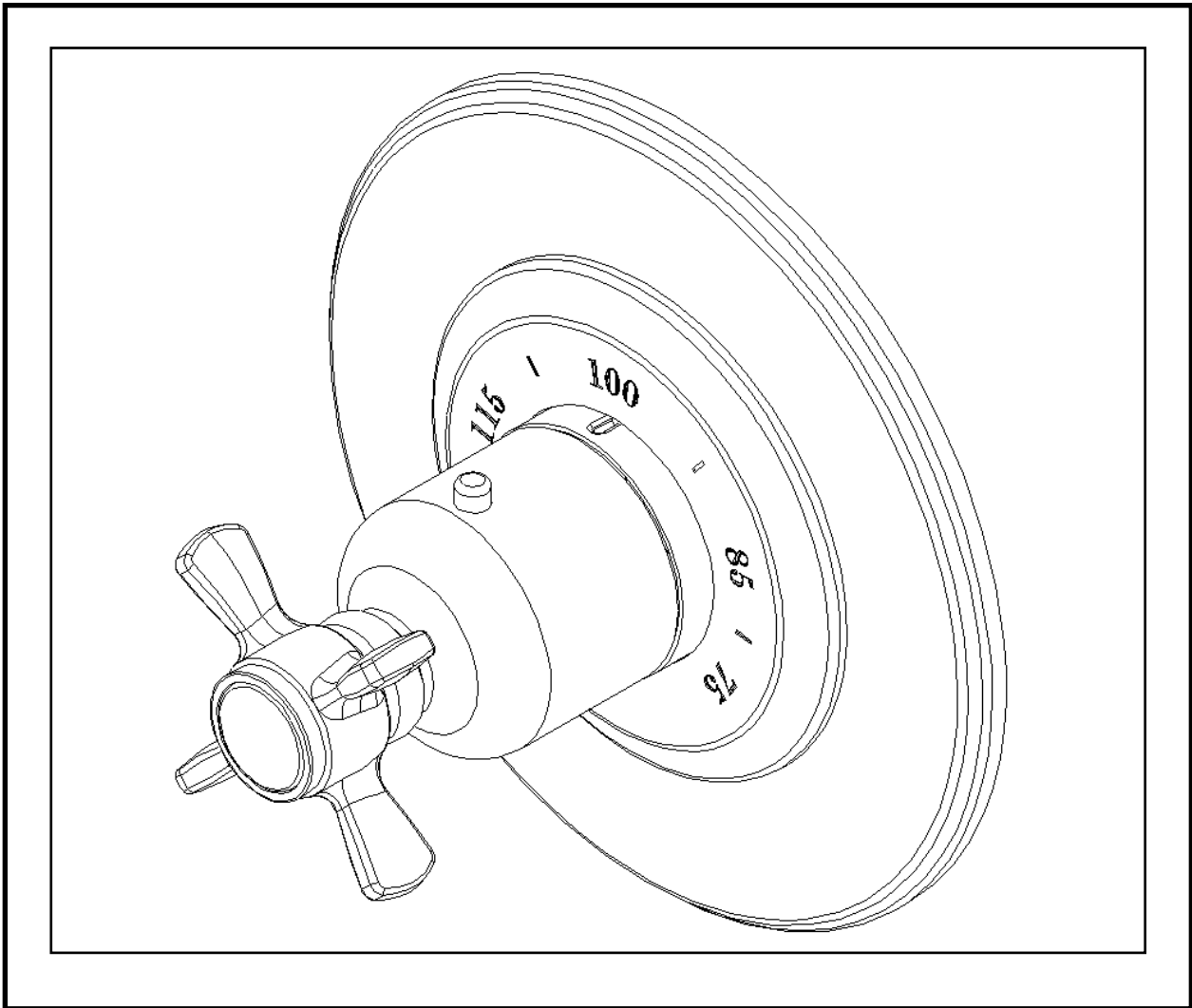

Installation Instructions



Thermostatic Valve and Trim
Model No. RH-5744

Restoration Hardware

Product Size Specification Diagram

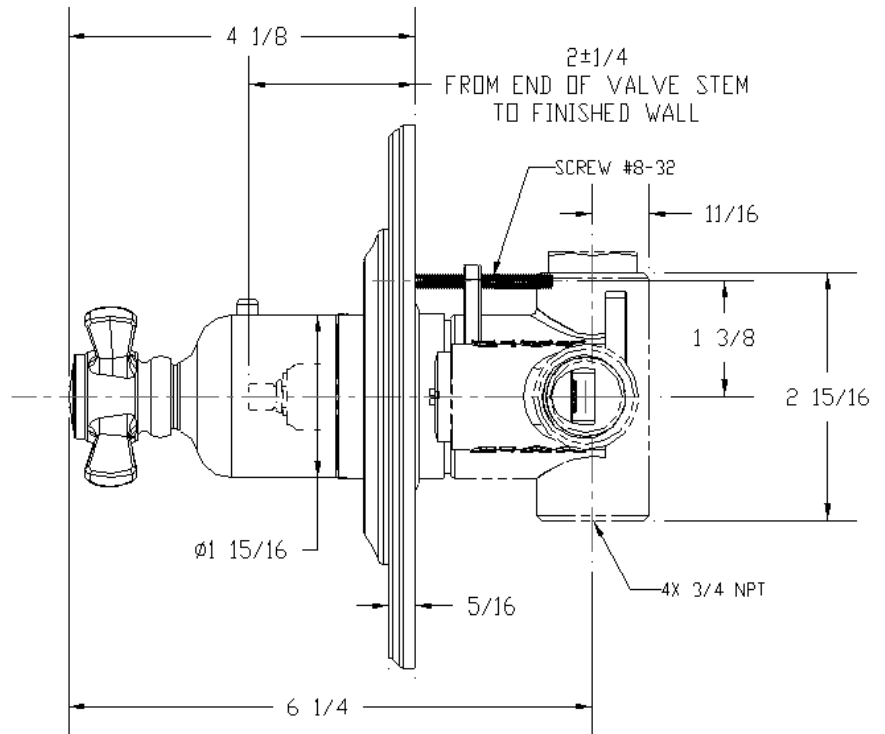

General Characteristics

In case of instantaneous heaters, hot water flow has to at least meet flow required by heater and maintain burning. (Specified by heater manufacturer)

Operating Specifications

Hot water supply temperature:

Maximum: Reference manufacturing specification

Minimum: 140°F

Minimum difference between hot and mixed temperature is: 50°F

Operating Pressure:

Maximum: 70 PSI

Minimum: 20 PSI

Operating pressure (on hot and cold line) should be kept as balanced as possible in order to assure maximum efficiency.

When the pressure is greater than 70 PSI, a pressure reducer is required. To be fitted before valve.

Technical Data

The temperature control knob is graduated from 75°F to 120°F with auto stop at 100° to avoid scalding.

Temperature limit setting of less than 120°F

Fit a stop valve/volume control between thermo valve outlet and end devise(s).

Plumbing Recommendations

- An independent water supply for both hot and cold is required. Do not pipe off ring main.
- Large runs of pipe work will cause frictional loss of pressure.
- The recommended main water supply piping to valve shall be 3/4" minimum
- If more than one valve is installed, the recommended main water supply piping to valve shall be 1" minimum, reducing to 3/4" within 24" of each valve.

(Ensure adequate supply from both hot and cold water can be maintained.)

Water By-Laws

The mixing valve should be installed in compliance with the water by-laws. For further details refer to the latest copy of by-laws guide or your local water authority.

I. Rough in Valve Installation

Note: Use Teflon tape or equivalent to seal all threaded port joints.

1. Do not remove mud cover from valve before locating mounting surface depth in the wall.
2. Do not turn the cartridge stem - temperature settings are pre-calibrated at the factory.
3. Install plug into one of the two outlet ports. Note: For proper valve operation **only one outlet port may be used.**
4. Mount valve to cross support using shims and screws (not included). Valve shall be perpendicular and fixed firmly to cross support to achieve proper trim attachment.
5. Place the cross support with valve between wall studs. The min./max. valve exposure template on the mud cover and vertical height desired within tub/shower enclosure determines the exact cross support placement. Attach cross support to wall studs.

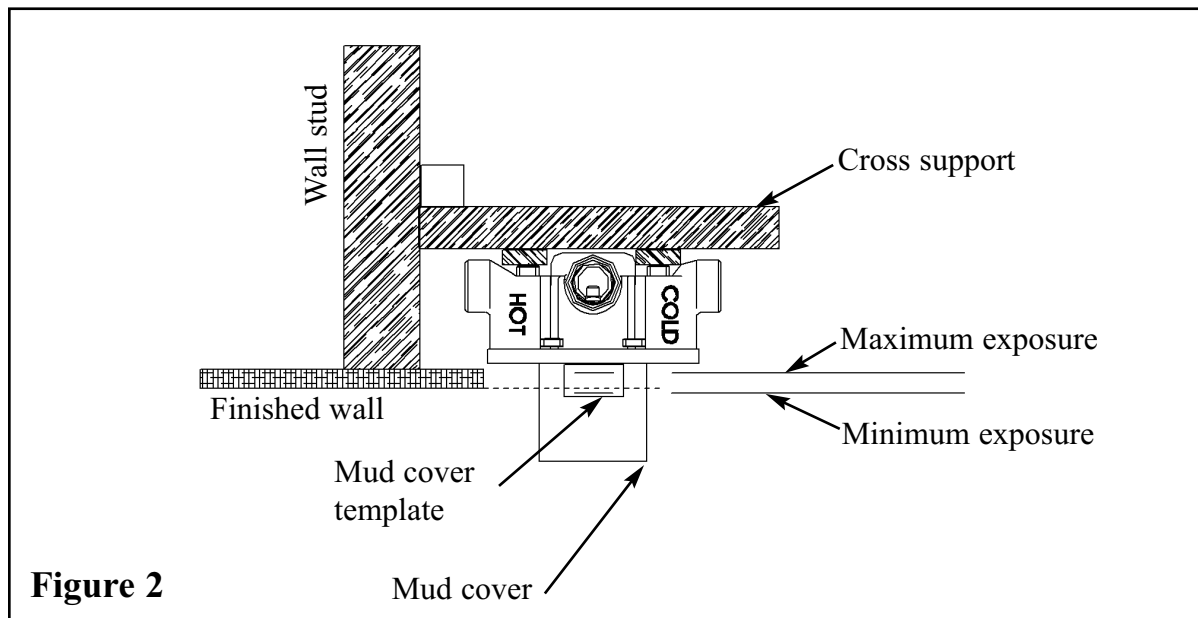
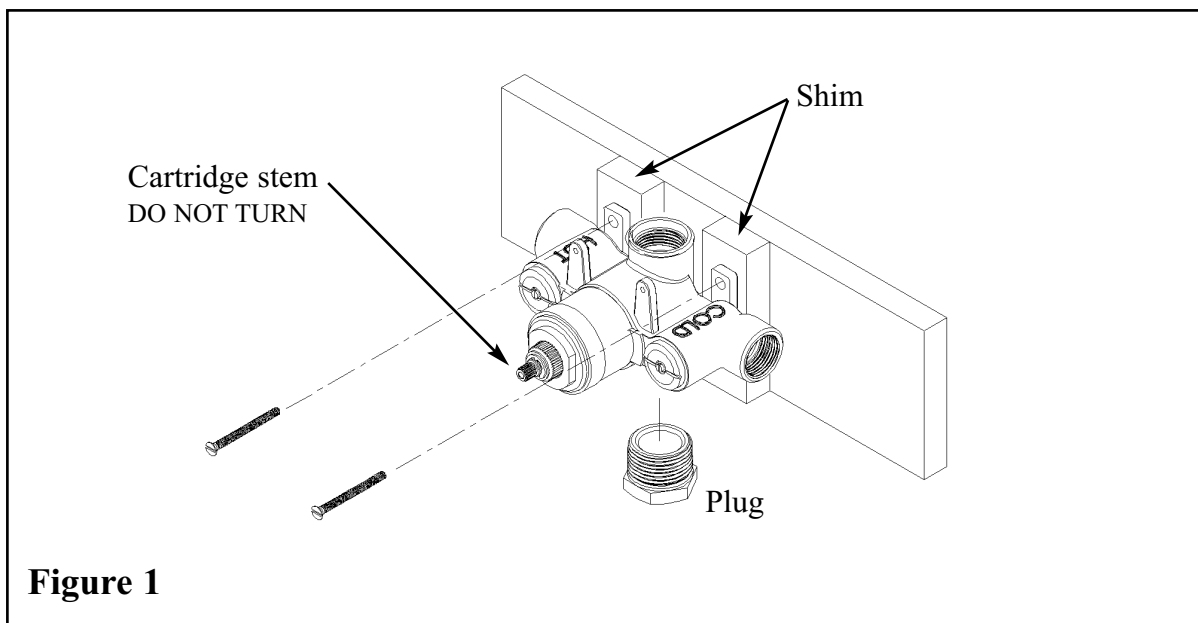

II. Connecting Water Supply

1. Thoroughly flush supply lines to remove any debris, metallic shavings, flux, etc.
2. Shut off water supply to valve.
3. Hot and cold water supplies **MUST** be connected to designated sides for proper operation of valve.
4. If solder/brazing the fitting connections, pre-assembly hot & cold adapter fittings to copper piping. Using Teflon tape or equivalent to attach adapter to appropriate inlet port.
Important: All excessive heat shall be a minimum of 4" from valve.
5. Connect outlet pipe to stop valve/volume control (not included), and from stop valve pipe to various end device(s).
6. Turn on water supply to valve and check for leaks.

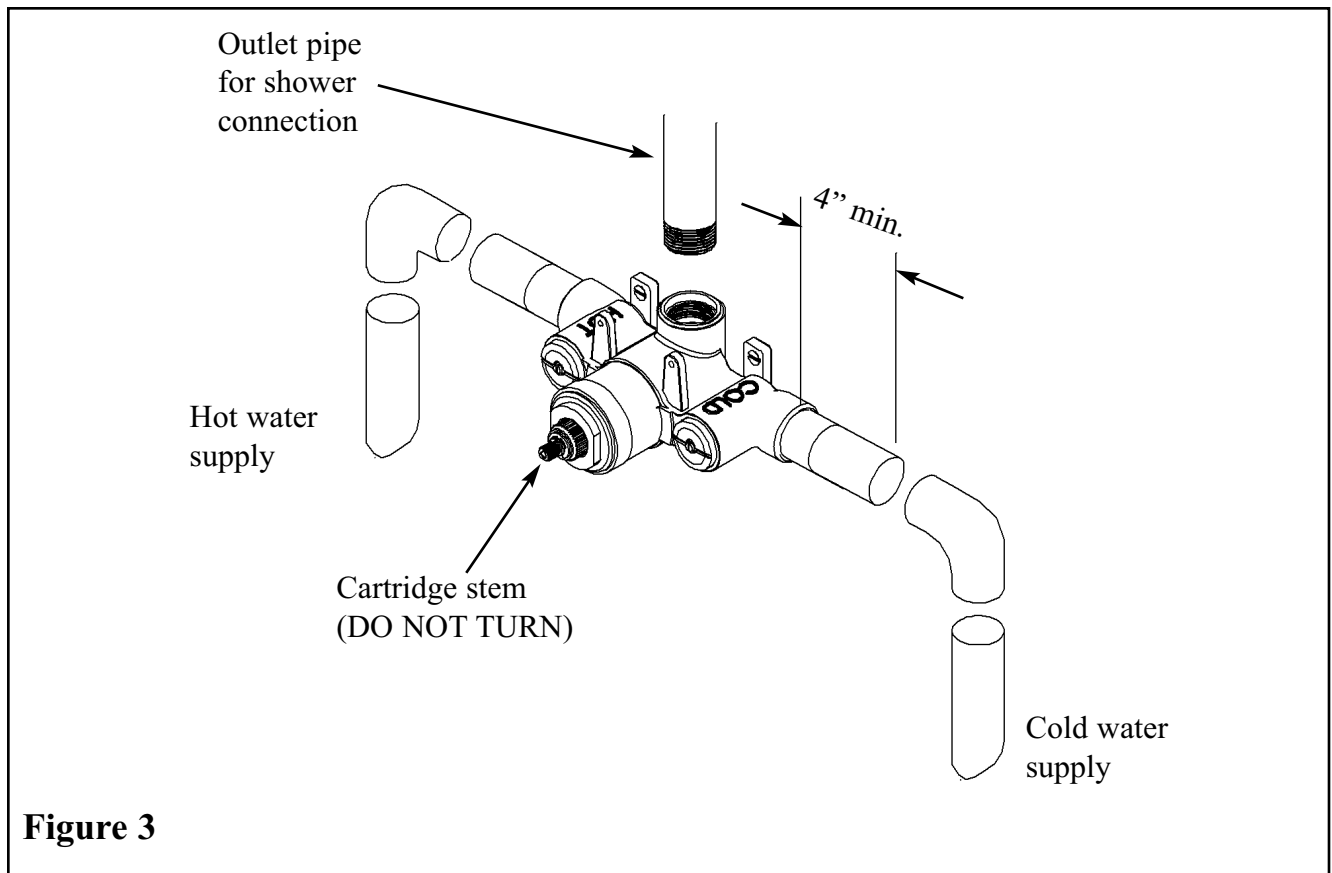

III. Installing Trim & Temperature Setting

1. Remove and discard mud cover and screws.
2. Slide sleeve over valve body with grooved notch to topside.
3. Slide cover plate with gasket over sleeve and attach with decorative screws provided (see Fig. 4).
4. Orient and position limit stop ring and temperature ring as shown below (see Fig. 5).
5. Open shut-off valve and verify water temperature at outlet device by using a thermometer.
NOTE: The safe and factory set temperature is 100°F. If the temperature needs to be adjusted follow step 6, otherwise skip to step 7.
6. Rotate cartridge stem to adjust temperature:
(clockwise = colder or counterclockwise = hotter)
7. Place bonnet onto cartridge stem with red button (100°F) positioned straight up and inline with notch on the sleeve (see Fig. 6).
8. Secure handle onto bonnet with long flat head screw.
9. Press cap onto decorative handle. Remove adhesive backing from button, align and press onto cap.

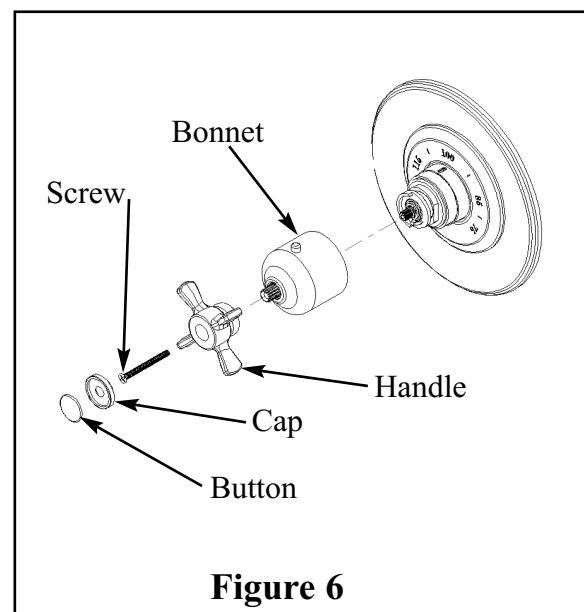
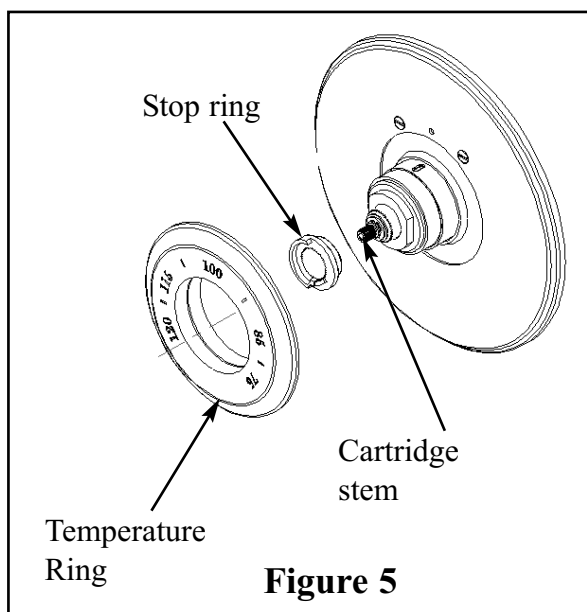
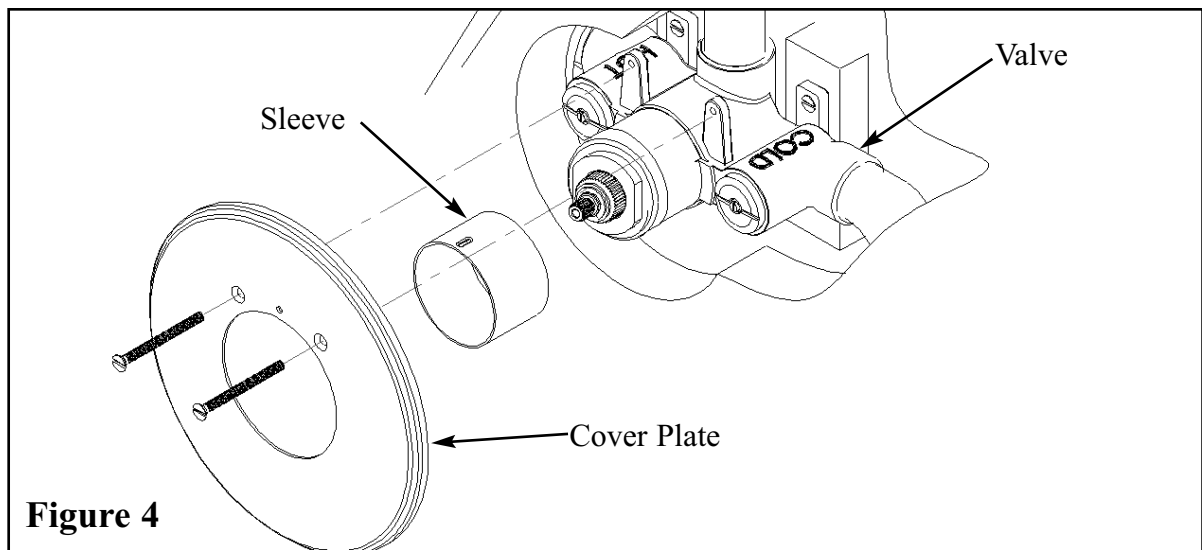

IV. Maintenance and Troubleshooting

The thermostatic valve has various screens that filter debris and unwanted particles that may damage the valves' cartridge and operation. Though years of use these screens may build up with impurities and lime scale, restricting the flow of water through the cartridge and or check valves. The following steps describe removal and cleaning procedure.

Cartridge (Reference Fig. 7)

1. Carefully remove the cap, screw, handle, bonnet, temperature ring, stop ring, cover plate and sleeve.
2. Shut off the water to cartridge by tightening center screw on each check valve, 7 turns maximum.
3. Unscrew the cartridge using 1-3/16" or adjustable wrench; gently remove cartridge from housing.
4. Clean the screens by rinsing the cartridge under running water. If necessary, soak in a 50/50 mix of white vinegar and water to remove lime scale.
5. Wipe cartridge and housing with wet cloth and apply a thin film of non-petroleum grease to o-rings. Do not use Vaseline.
6. Carefully install cartridge into housing and tighten to 10 ft-lbs.
7. Fully open check valves and inspect for leaks.
8. Check operation and flow. If improved, proceed to step 9, otherwise refer to check valve section.
9. Reinstall trim and set temperature per section III.

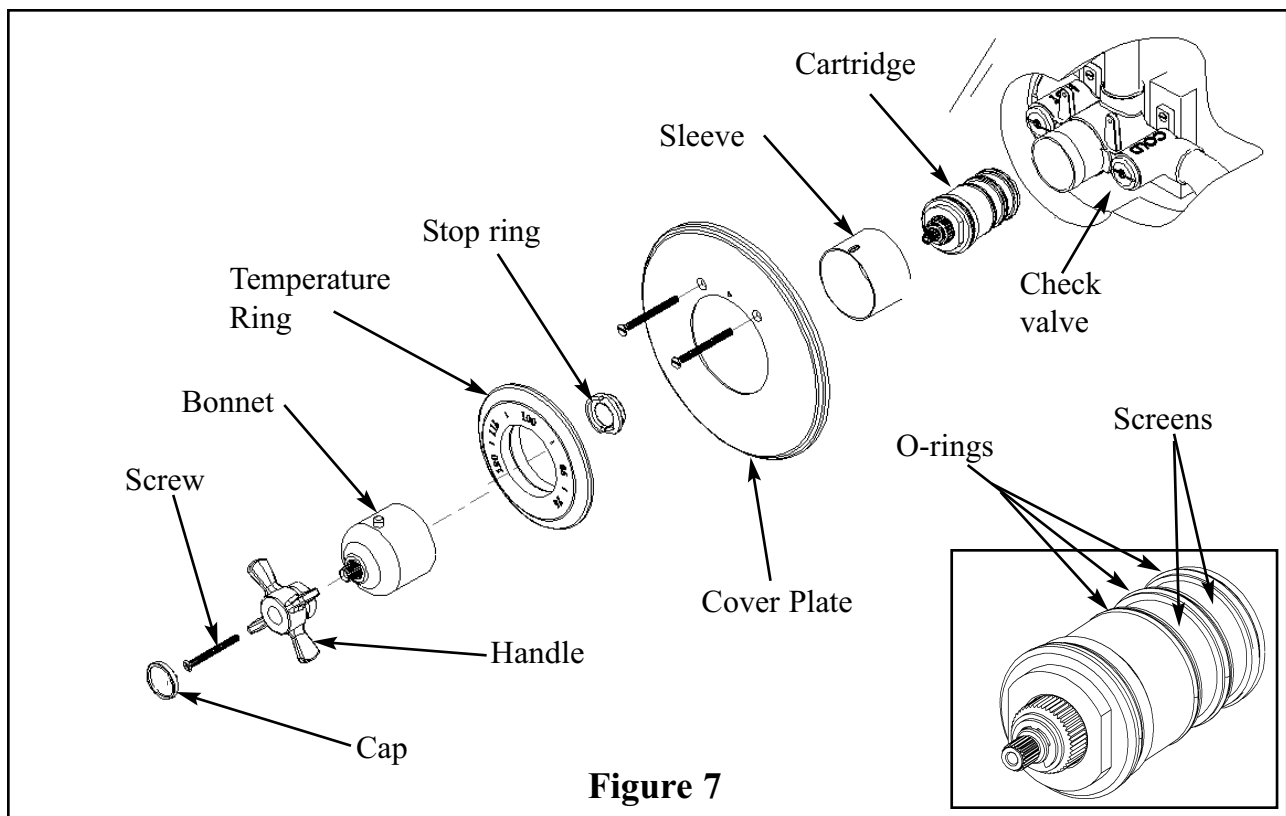
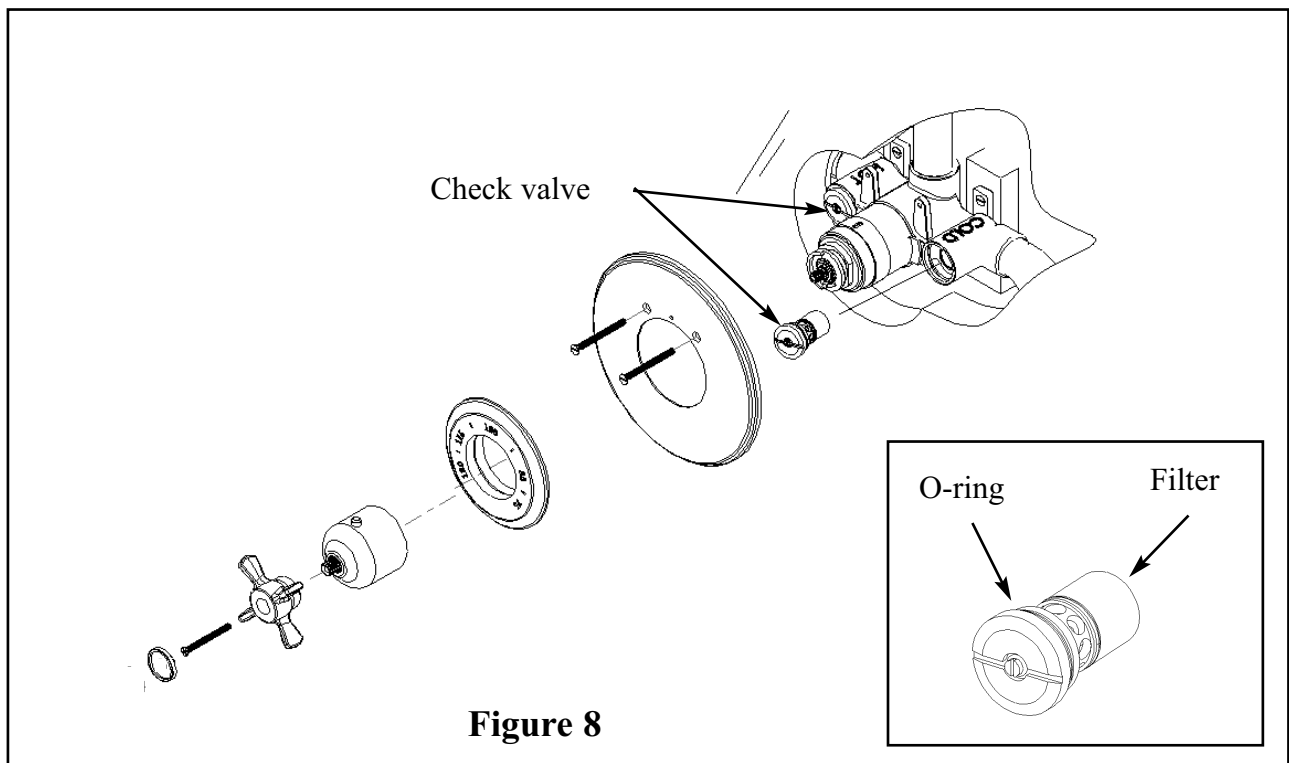

Figure 7

Check valve (Reference Fig. 8)

1. Turn water supply to valve inlets off.
2. Tighten center screw on check valve inward until it clears bottom on check valve slot.
3. Unscrew check valve with large bladed screwdriver.
4. Remove check valve and clean per previous step 4 and 5.
5. Replace valve back into housing, unscrew center and re-close to 7 turns max.
6. Turn on water supply to valve inlets.
7. Fully open the check valve screws and inspect for leaks.
8. Reinstall trim and set temperature per section III.



Care and Cleaning

The lustrous finish on your Restoration Hardware Bathware fixture should be treated with care. Improper handling or cleaning can damage the surface of any metal finish. Use a soft cloth to wipe clean. Avoid harsh abrasive cleaner. Water contains lime and other mineral deposits that will be left on the surface after the water has evaporated. You can prevent these deposits from forming by always wiping the fixture dry immediately after use.

Technical Support and Customer Service

For technical support in the installation of your Restoration Hardware Bathware fixture, please call 1-866-417-5207 weekdays between the hours of 7:00am and 4:00pm PST.

For other questions regarding your order, to order additional components of the Restoration Hardware Bathware Collection, to order replacement parts, or to address warranty issues, please contact Restoration Hardware Customer Service at 1-877-747-4671.