

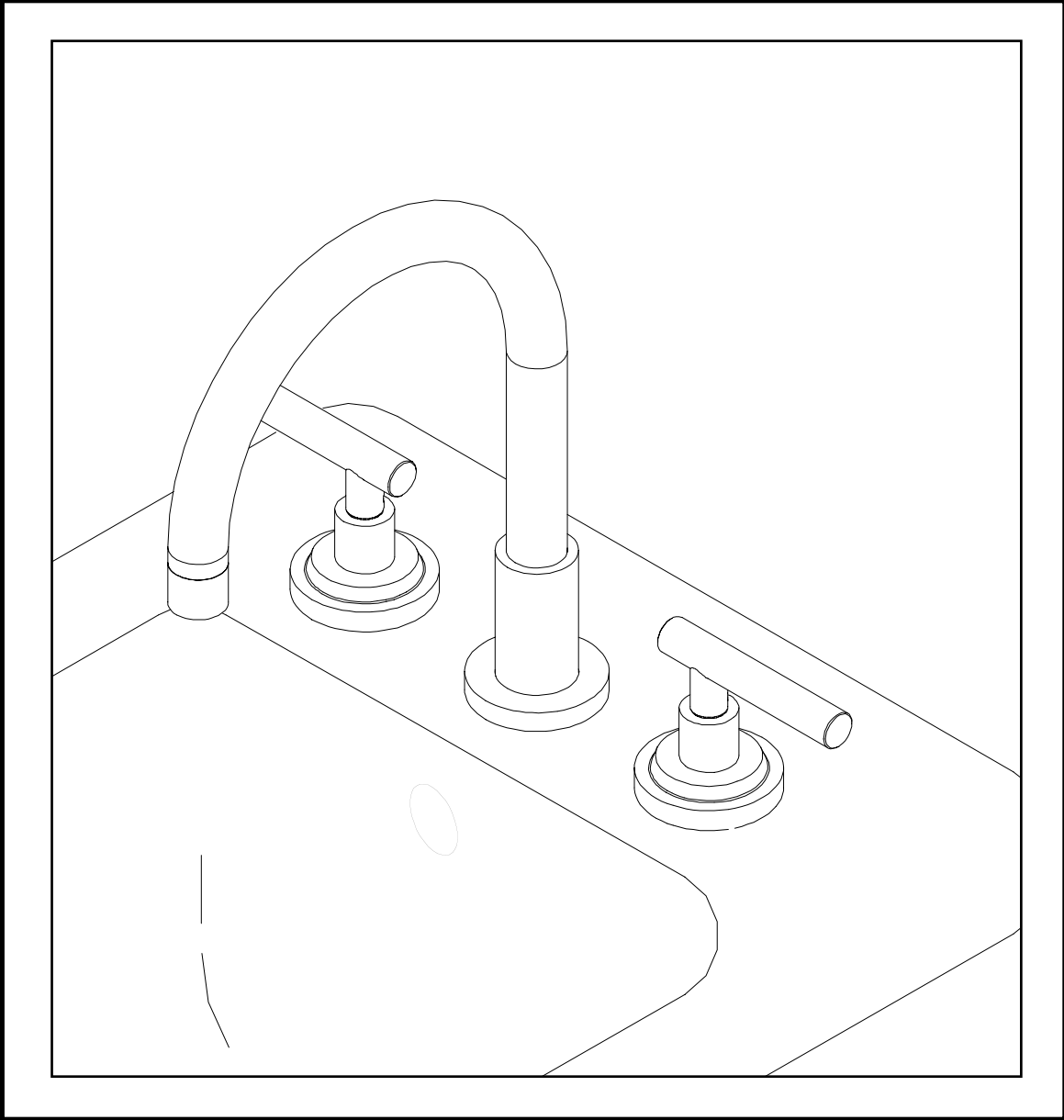

INSTALLATION INSTRUCTIONS



MODEL: SPRITZ

RH-5660

Restoration Hardware Roman Tub Product Size Specification Diagram

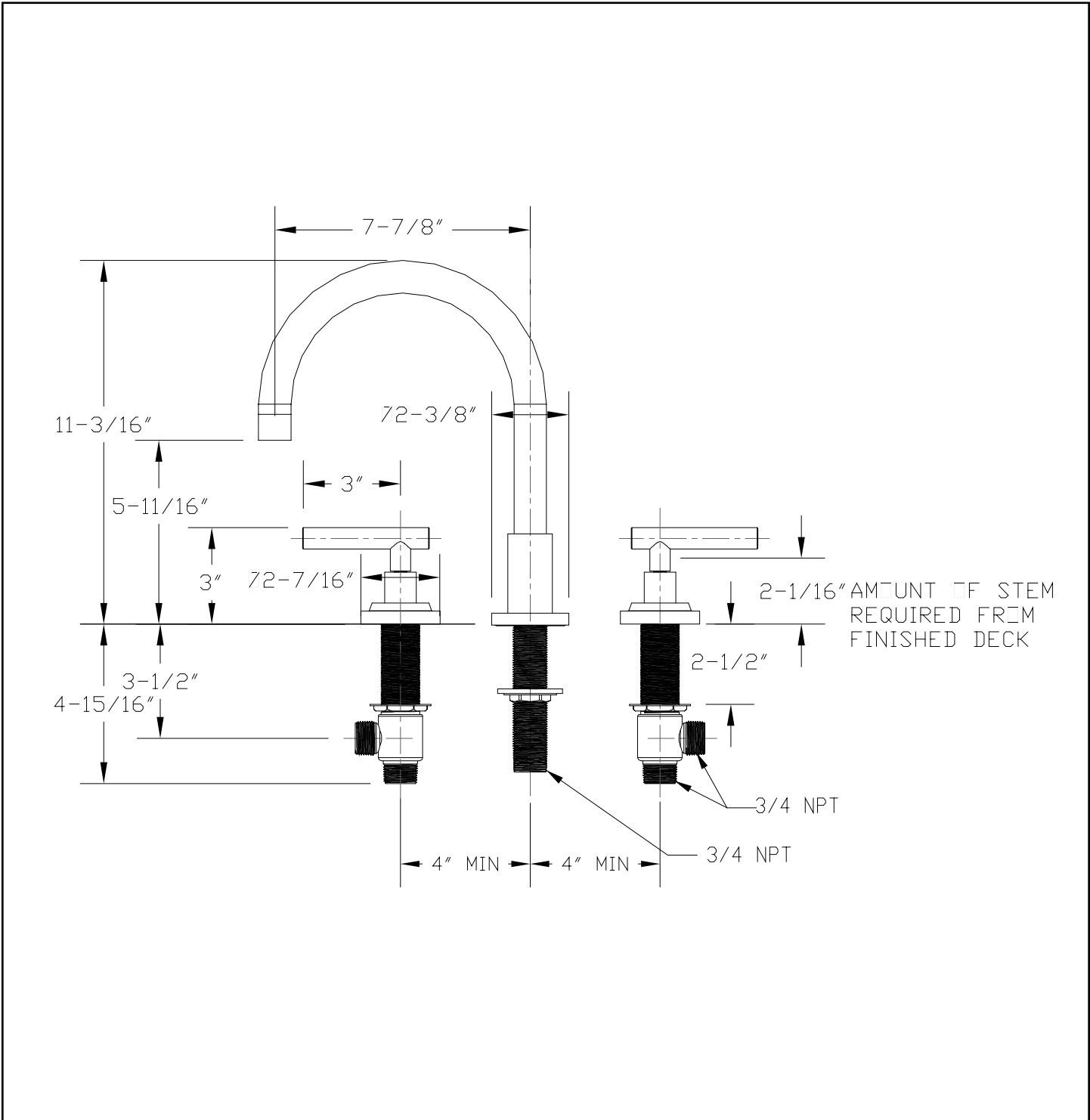

Recommended Deck Hole Size 1-1/4" Diameter
Dimensions are in Inches and Approximation of a Typical Installation

Common tools needed:

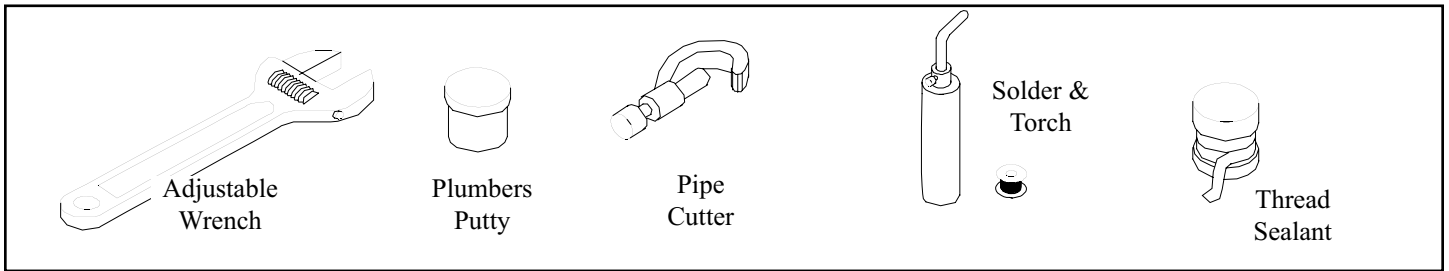

Installation Instructions

We Recommend Installation by a Licensed Plumbing Professional

1. Spout Assembly

- Apply thread sealant to one end of NIPPLE (2) and tighten into SPOUT (1).
- Seat O-RING (4) into groove on the underside of base RING (3).
- Insert NIPPLE (2) through base RING (3) and deck hole. (Apply putty or silicone to underside of base RING (3).
- Place WASHER (5) and NUT (6) onto NIPPLE (2), align SPOUT (1) and firmly tighten down NUT (6) using a wrench.

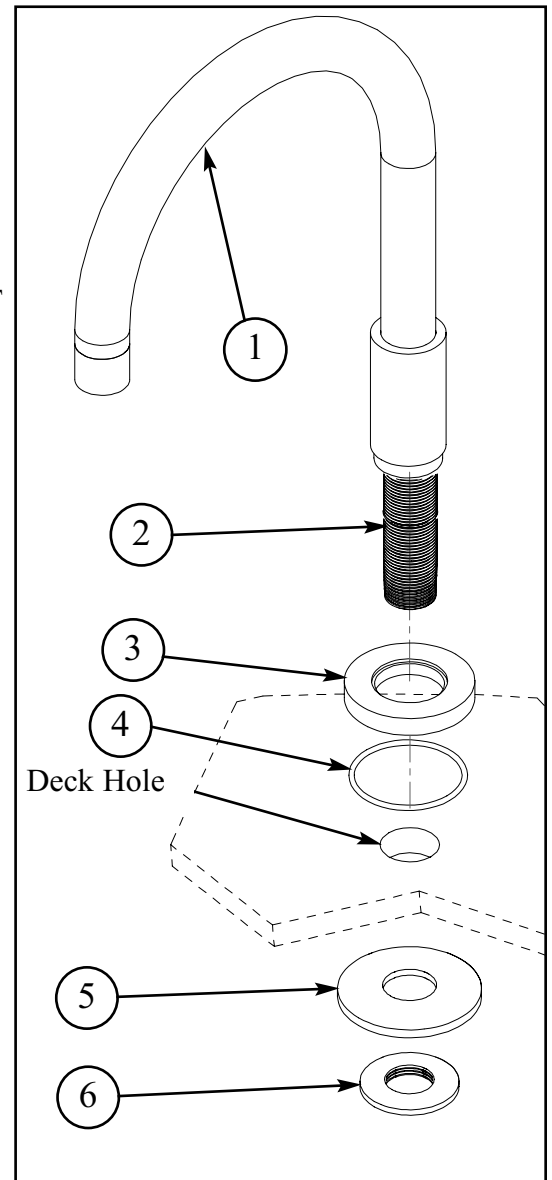

2. Valve Assembly

Note: Blue marked stem is COLD and red marked stem is HOT.

- Place FLANGE NUT (1) onto VALVE BODY (2).
- Insert VALVE BODY (2) through deck hole from underside of deck. VALVE BODY (2) should extend 2-1/16" above finished deck surface. If necessary adjust lower FLANGE NUT (1).
- Place FLANGE NUT (1) onto upper portion of VALVE BODY (2).
- Set VALVE BODIES (2, 2a) so that their side outlets are facing toward location of spout and tighten up FLANGE NUT (1)

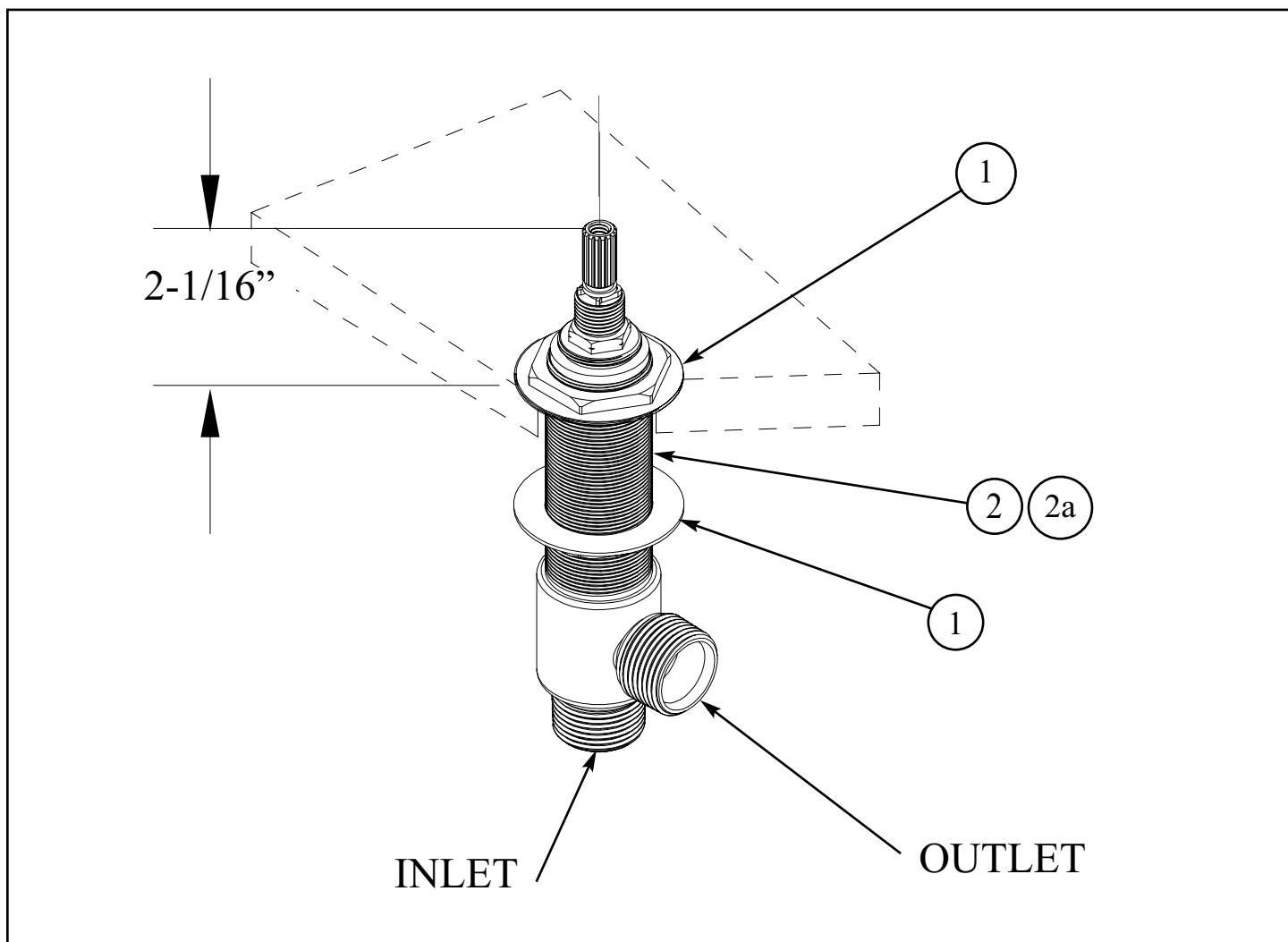

3. Water Supply Connections

Note: Piping and plumbing fittings are not supplied. It is recommended that all solder operations be performed prior to attaching fittings to valves. Usage of access panel(s) is highly recommended.

- The most common methods of water connections are one of the following:
 - a. Flexible Stainless Steel braided hoses
 - i. Access panel(s) are required by plumbing code (UPC).
 - ii. No soldering or brazing is required.
 - b. Rigid Copper tubing / piping
 - i. Requires soldering or brazing.
 - ii. All soldering must be performed a minimum of 4" from valve ports.
 - iii. Brazing must be performed before attaching to valves.
- Make all necessary connections as shown.

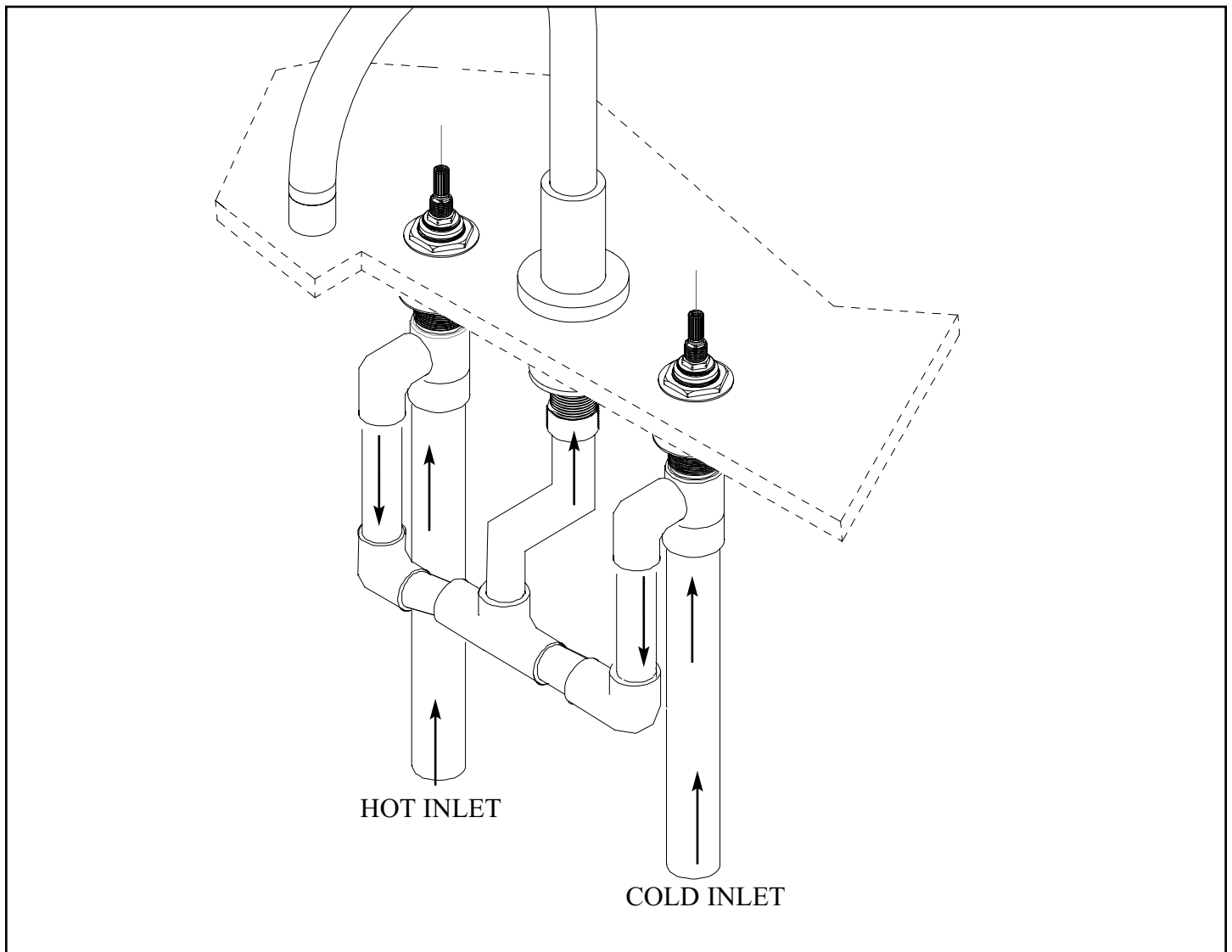

4. Handle Installation

- Turn VALVE STEM (4) to OFF position.
- Seat O-RING (4) into groove on the underside of ESCUTCHEON (3).

- Place ESCUTCHEON (3) onto VALVE STEM (5) and thread BONNET (2) until snug against ESCUTCHEON (3).

- Place HANDLE (1) onto VALVE STEM (5). Check alignment, if necessary reposition handle on stem or rotate body for proper alignment. **DO NOT** loosen cartridge stem.

Secure HANDLE (1) into place by tightening

SCREW (6) with wrench provided.
Note: Allow minimal space between HANDLE (1) and BONNET (2).

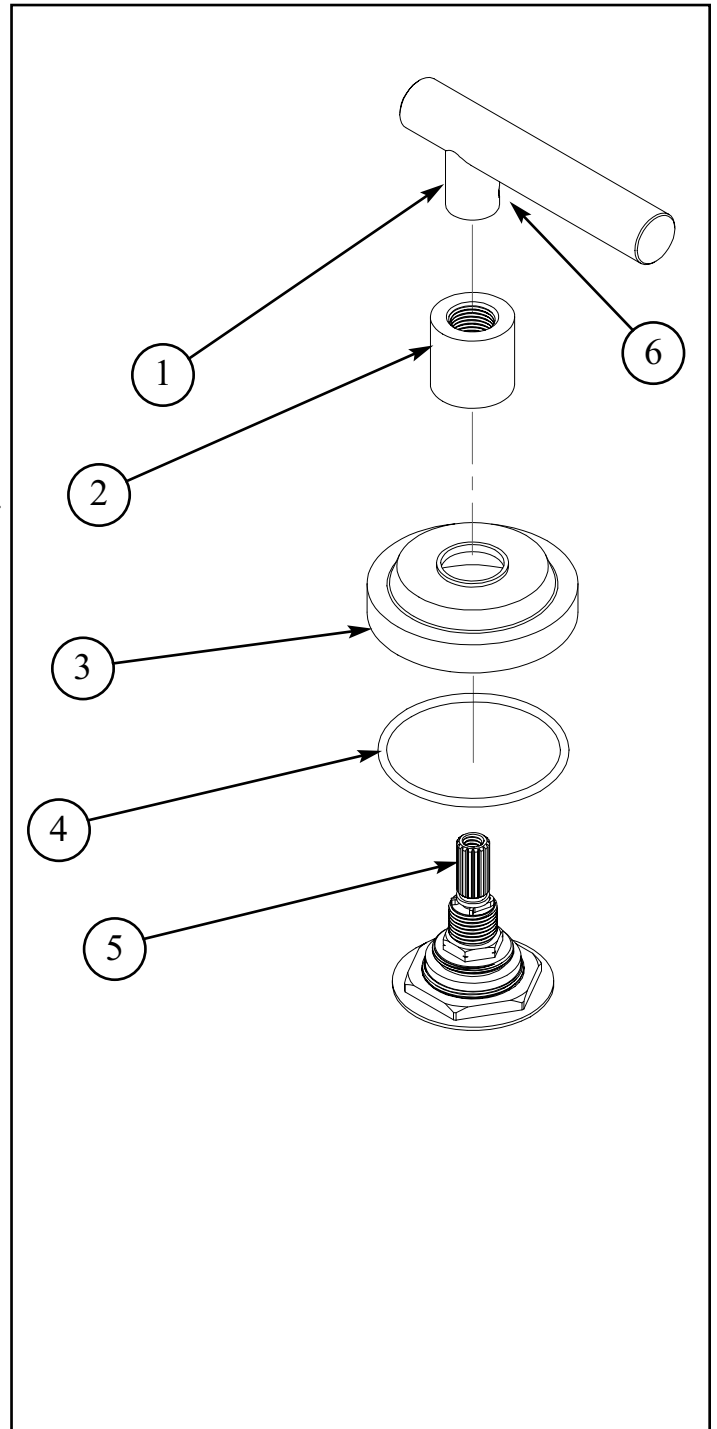

5. Test Installed Faucet

- With handles in the OFF position, turn on water supplies and check all connections for leaks.
- Remove AERATOR (2) from SPOUT (1).
- Open both hot and cold valves and allow water to run for several minutes to flush debris from installation.
- Turn water OFF and reattach AERATOR (2) to SPOUT (1).

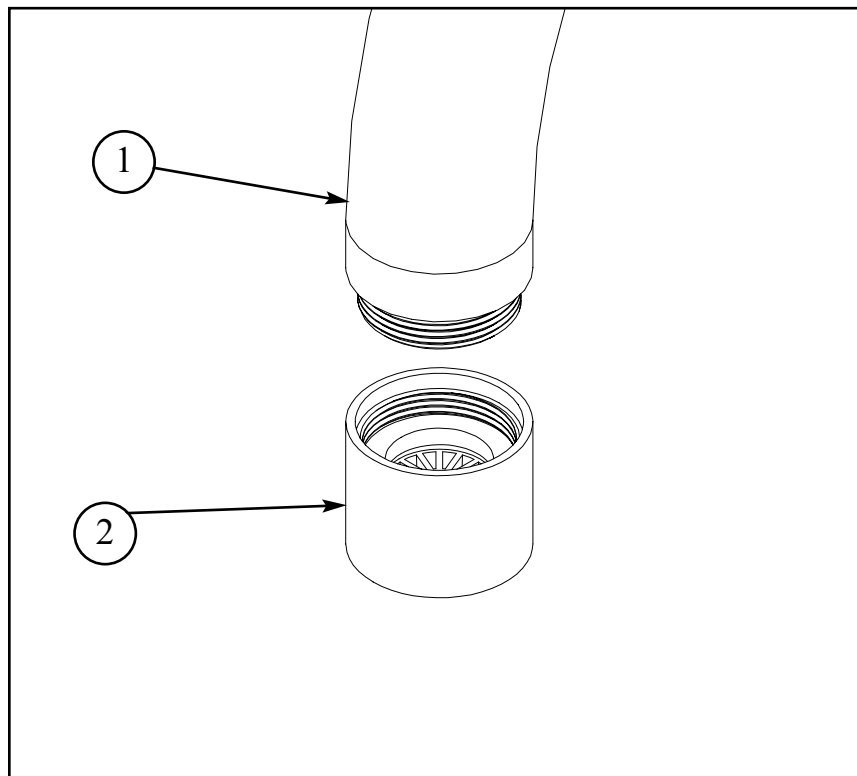

Care and Cleaning

The lustrous finish on your Restoration Hardware Bathware fixture should be treated with care. Improper handling or cleaning can damage the surface of any metal finish. Use a soft cloth to wipe clean. Avoid harsh abrasive cleaner. Water contains lime and other mineral deposits that will be left on the surface after the water has evaporated. You can prevent these deposits from forming by always wiping the fixture dry immediately after use.

Technical Support and Customer Service

For technical support in the installation of your Restoration Hardware Bathware fixture, please call 1-866-417-5207 weekdays between the hours of 7:00am and 4:00pm PST.

For other questions regarding your order, to order additional components of the Restoration Hardware Bathware Collection, to order replacement parts, or to address warranty issues, please contact Restoration Hardware Customer Service at 1-877-747-4671.